

34-03-001 , Air Conditioning (03/96 ->) , Without SATC module, petrol engines except 2,9 I V6 12V

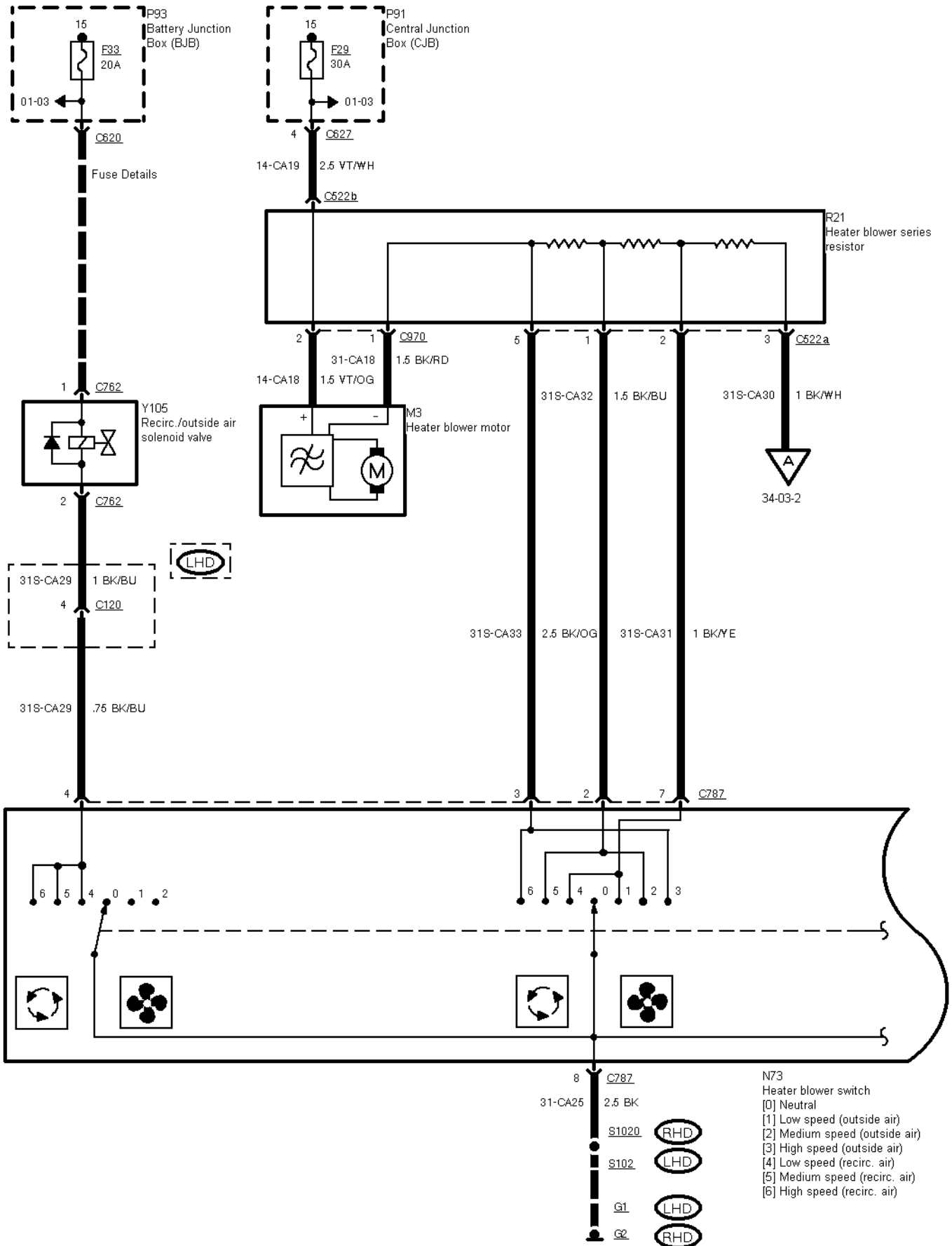

34-03-002 , Air Conditioning (03/96 ->) , Without SATC module, petrol engines except 2,9 I V6 12V

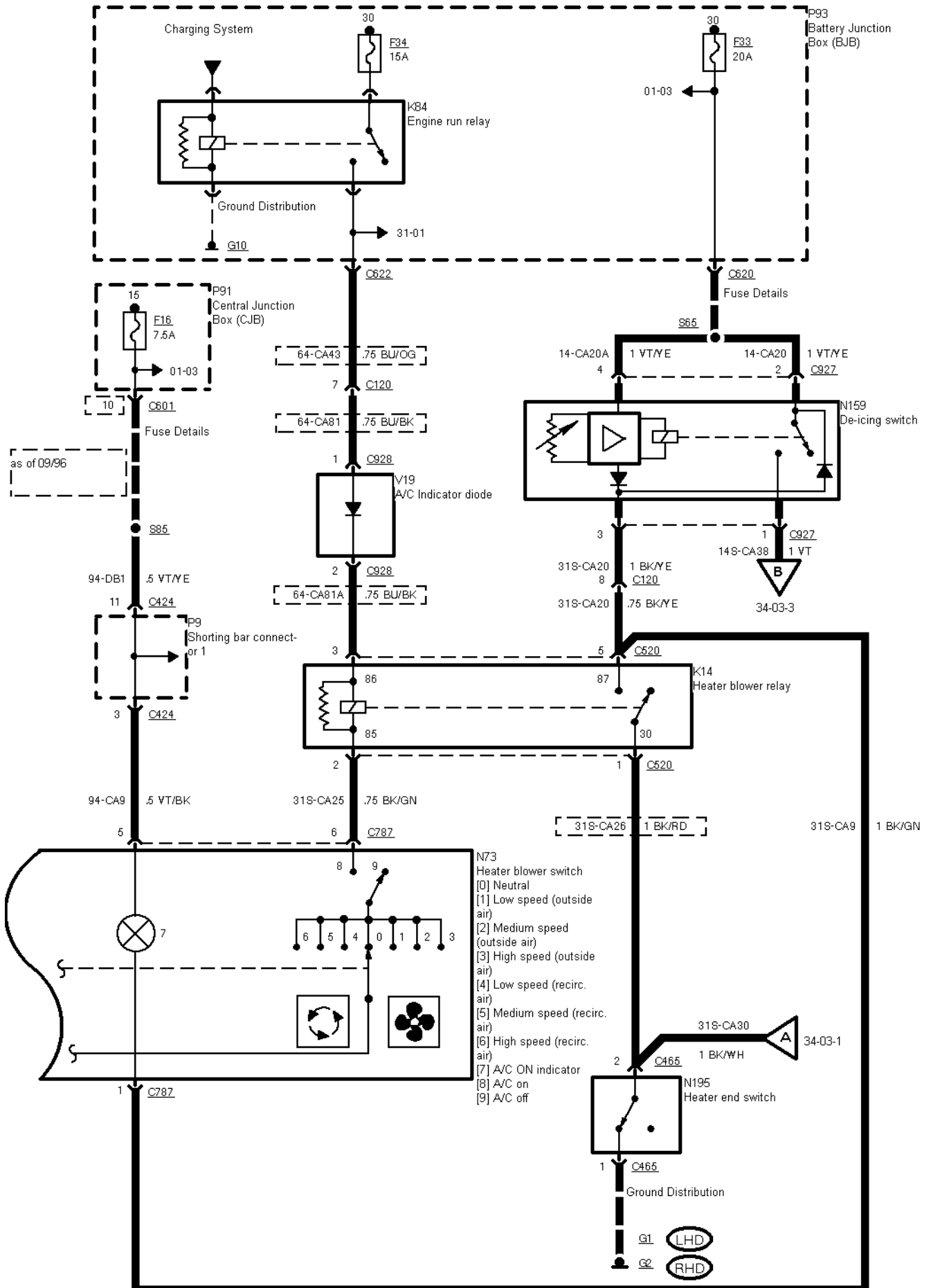

34-03-003 , Air Conditioning (03/96 ->) , Without SATC module, petrol engines except 2,9 I V6 12V

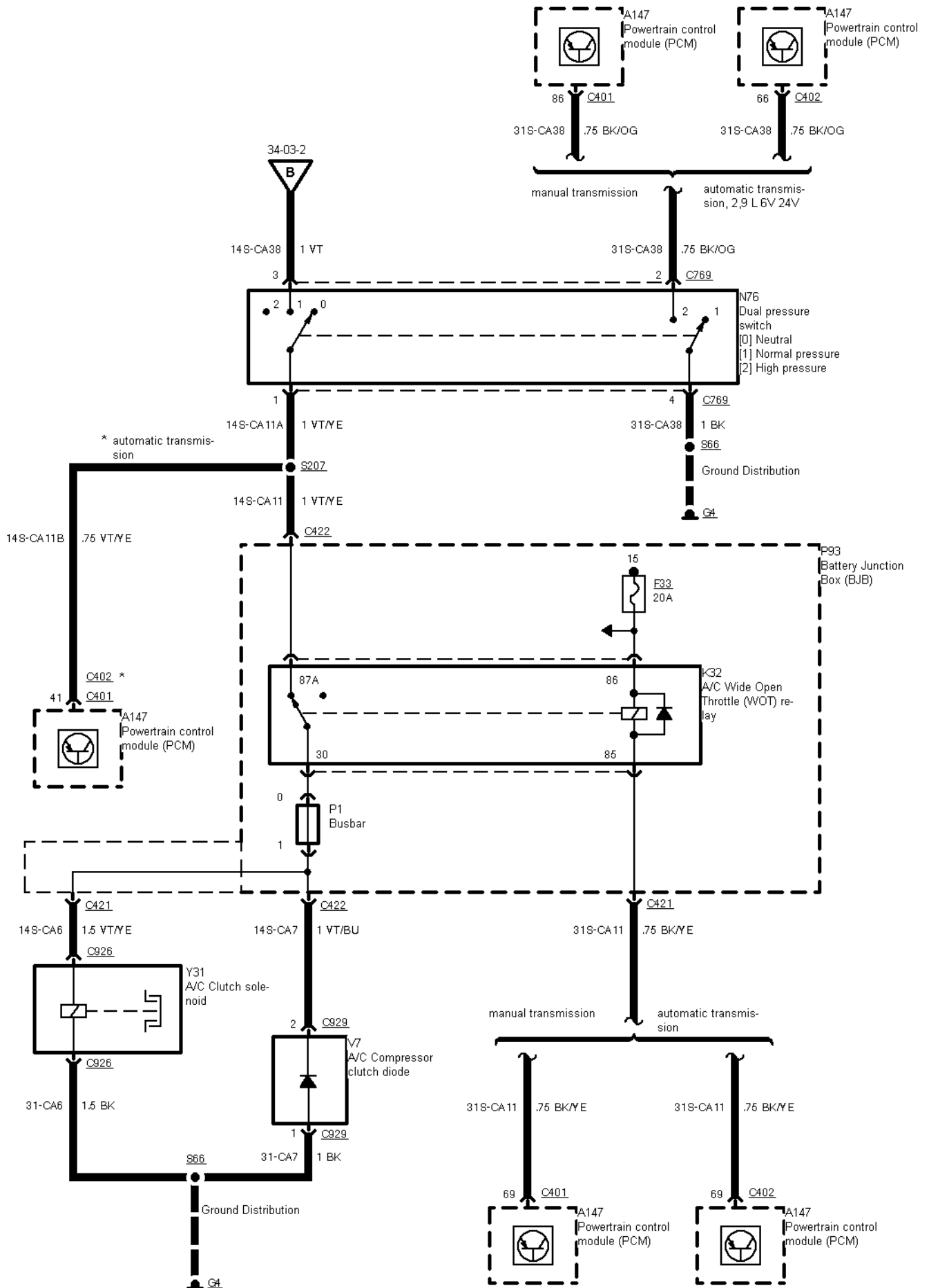

34-03-004 , Air Conditioning (03/96 ->), Engine cooling fan, petrol engines except 2,9 I V6 12V

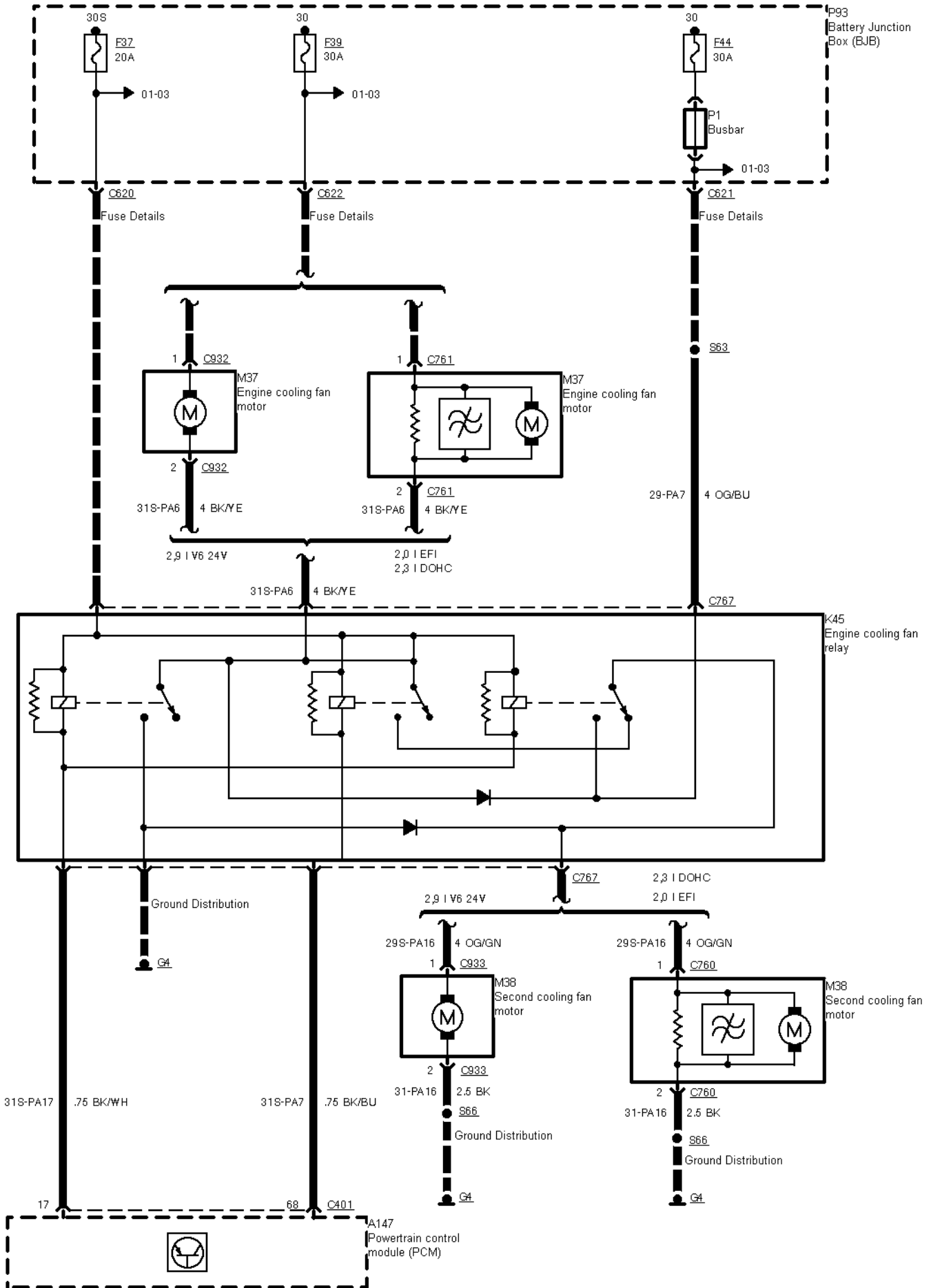

34-03-005 , Air Conditioning (03/96 ->) , Without SATC module, 2,9 I V6 12V, TCI Diesel from 03/96 to 09/96

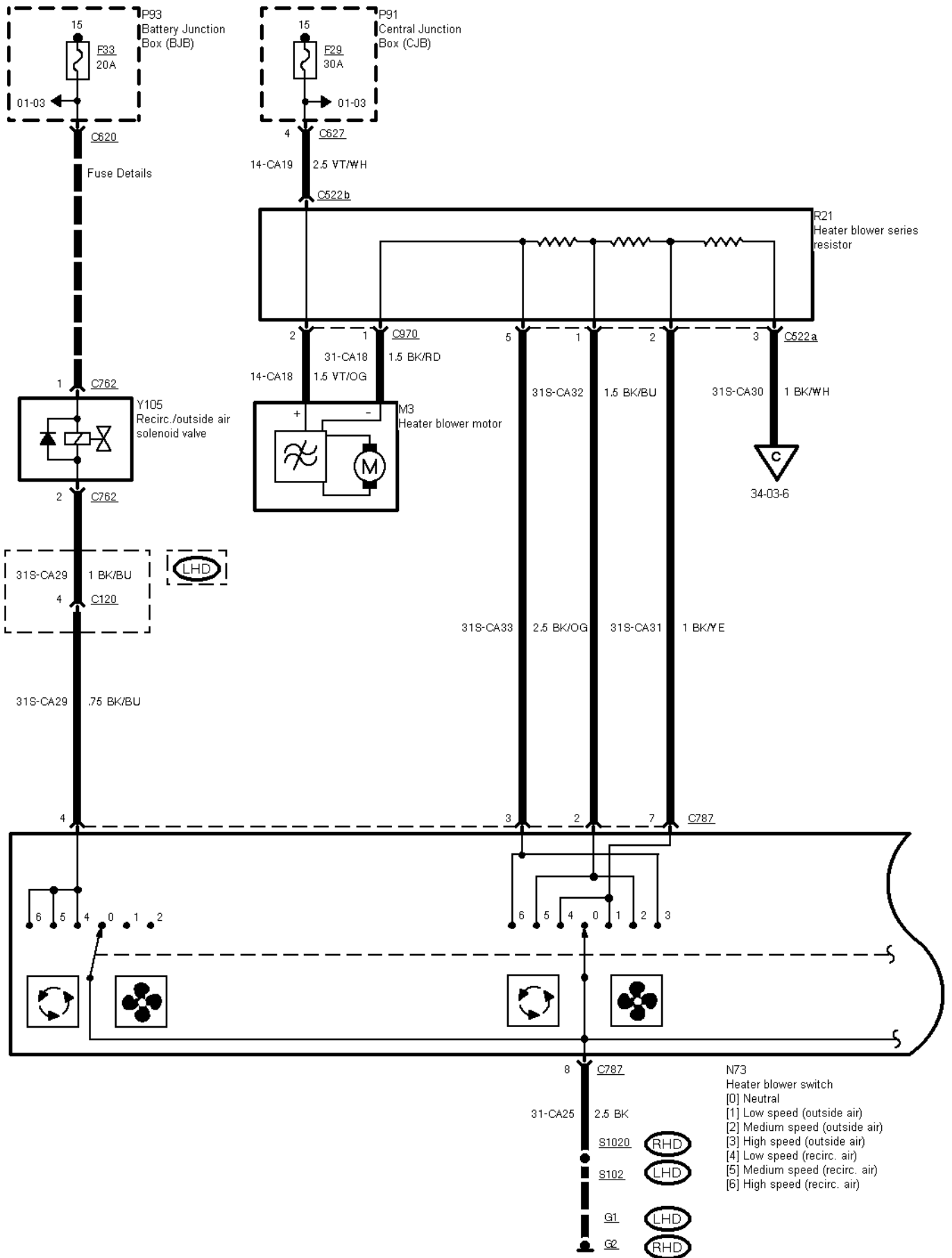

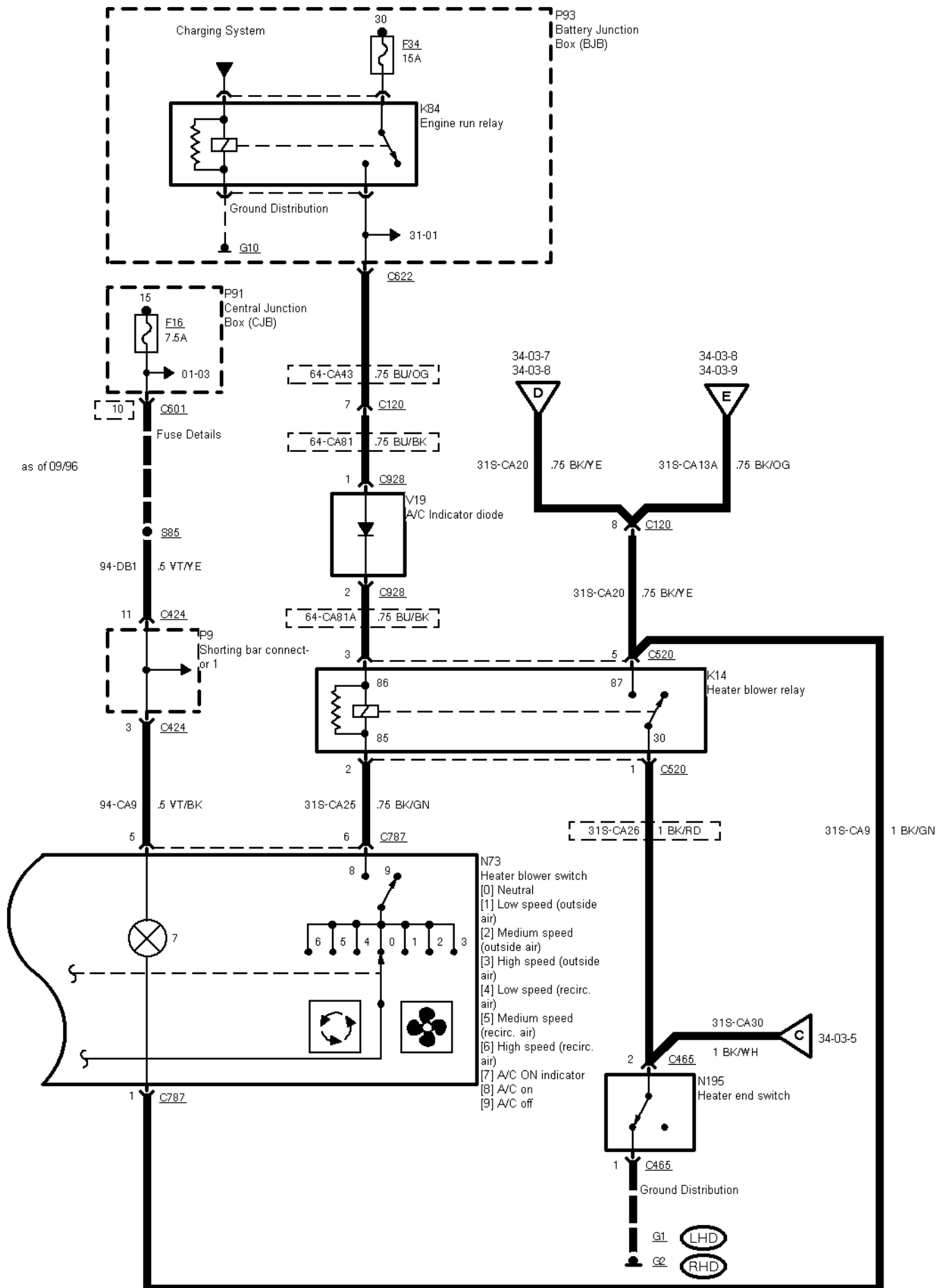

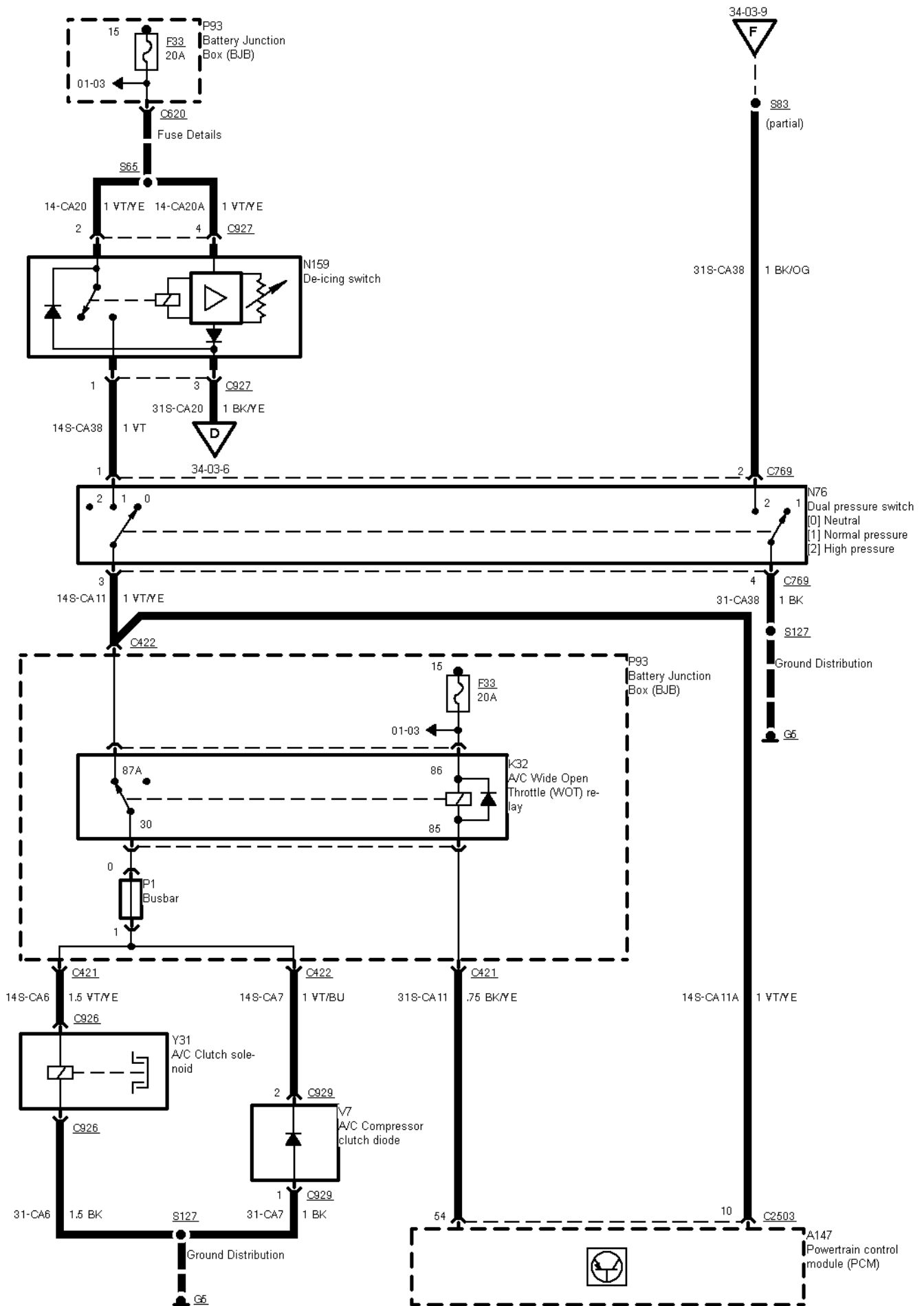

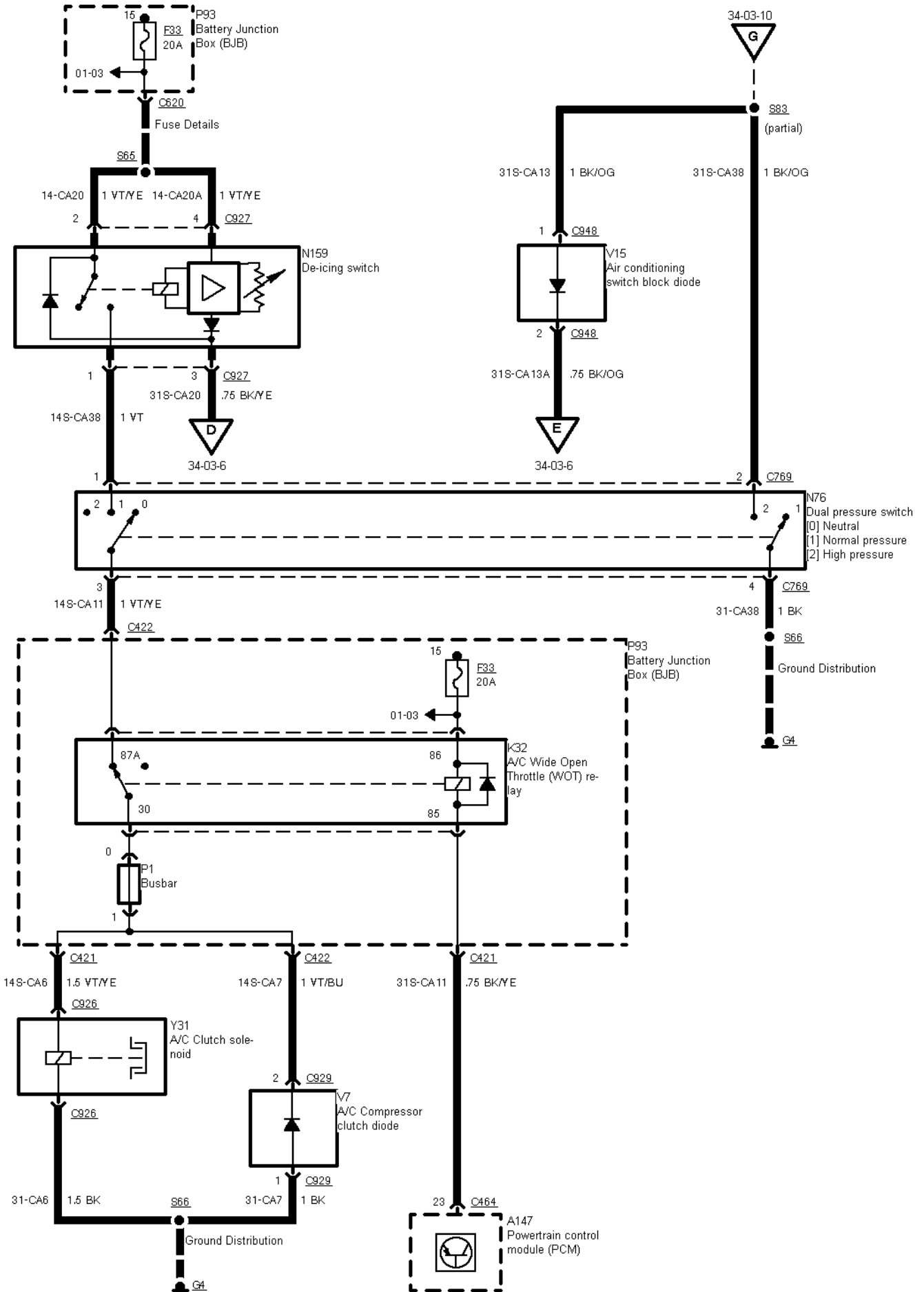

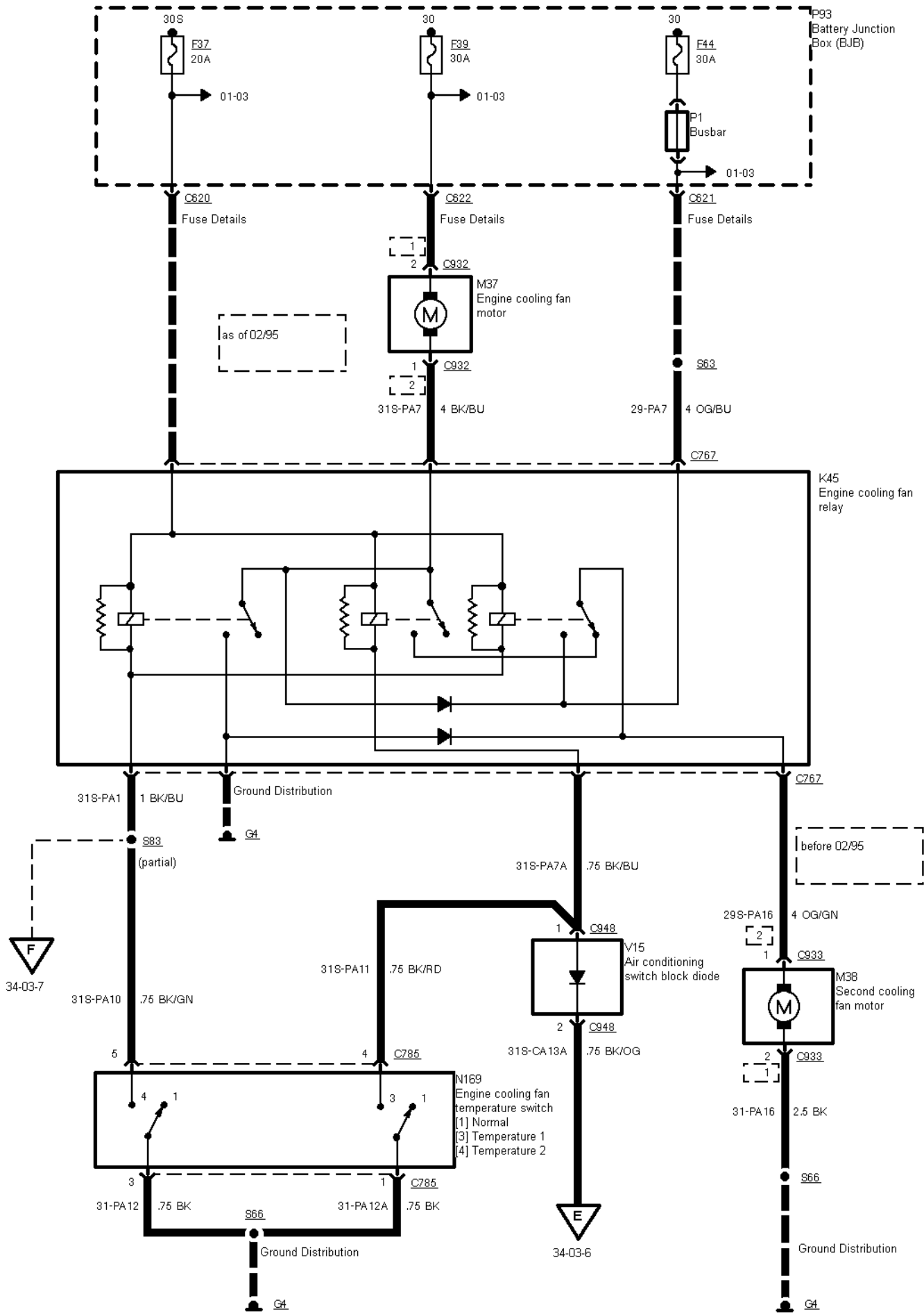

34-03-010 , Air Conditioning (03/96 ->) , Engine cooling fan, TCI Diesel

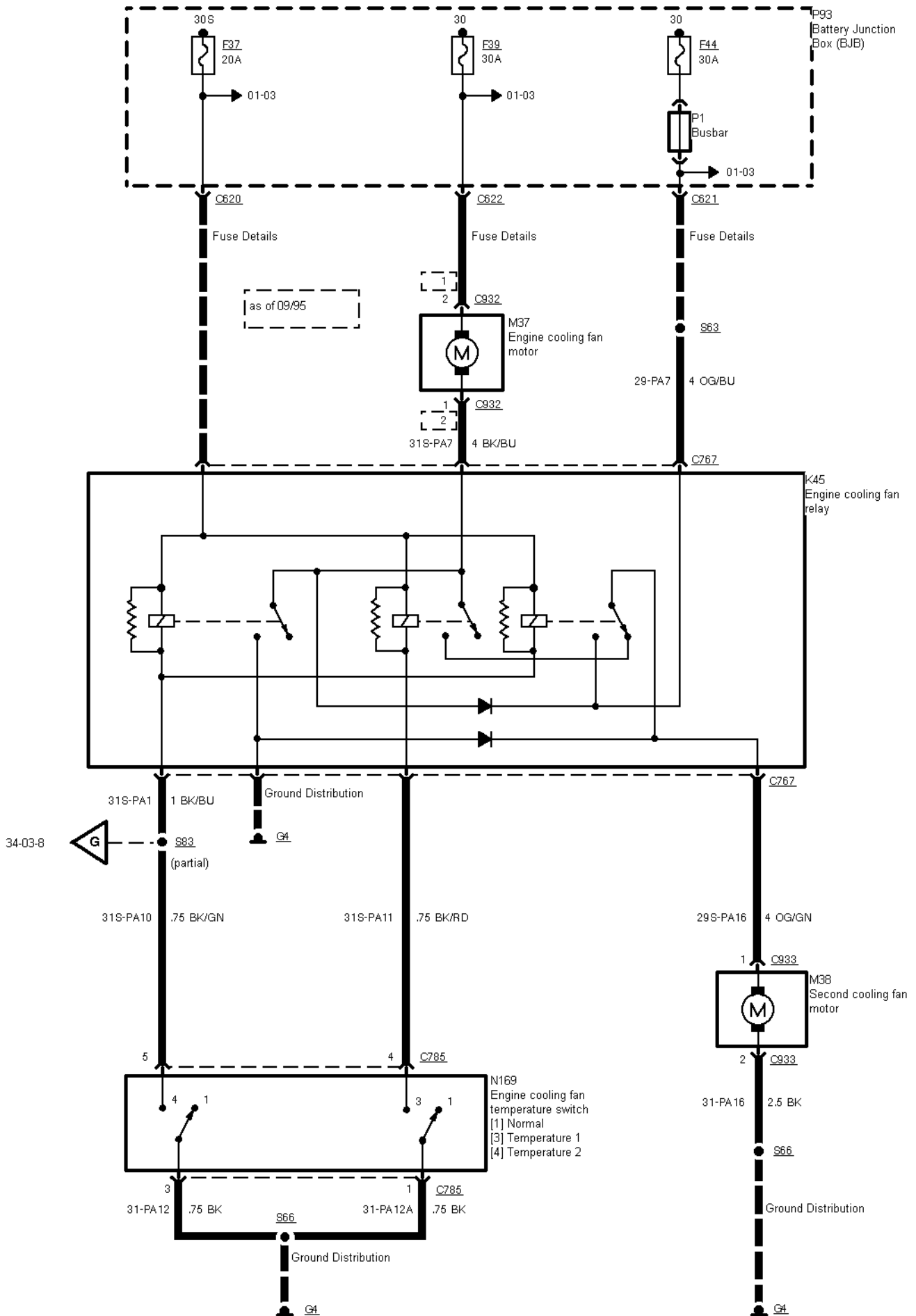

34-03-011 , Air Conditioning (03/96 ->) , Without SATC module, TCI Diesel as of 09/96

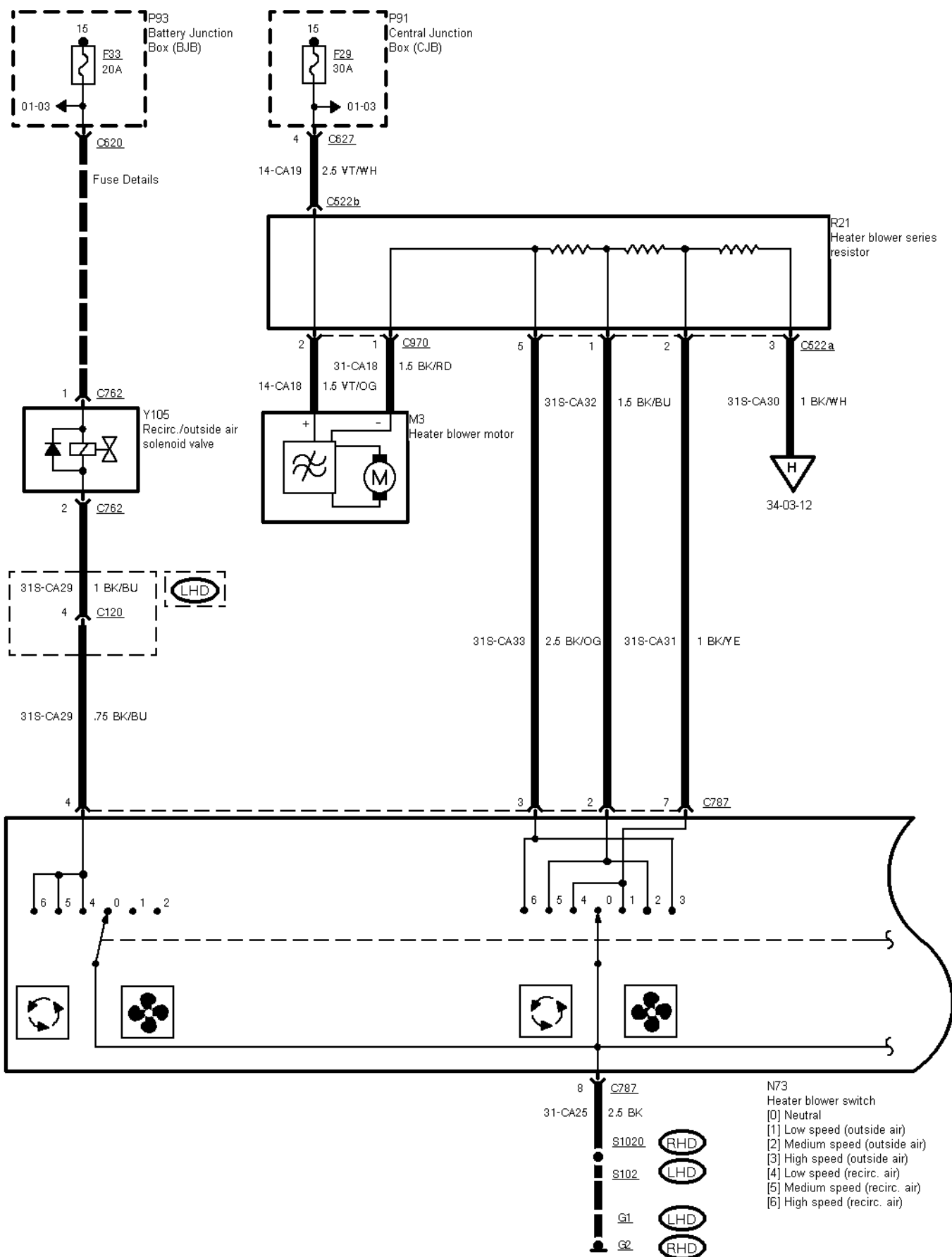

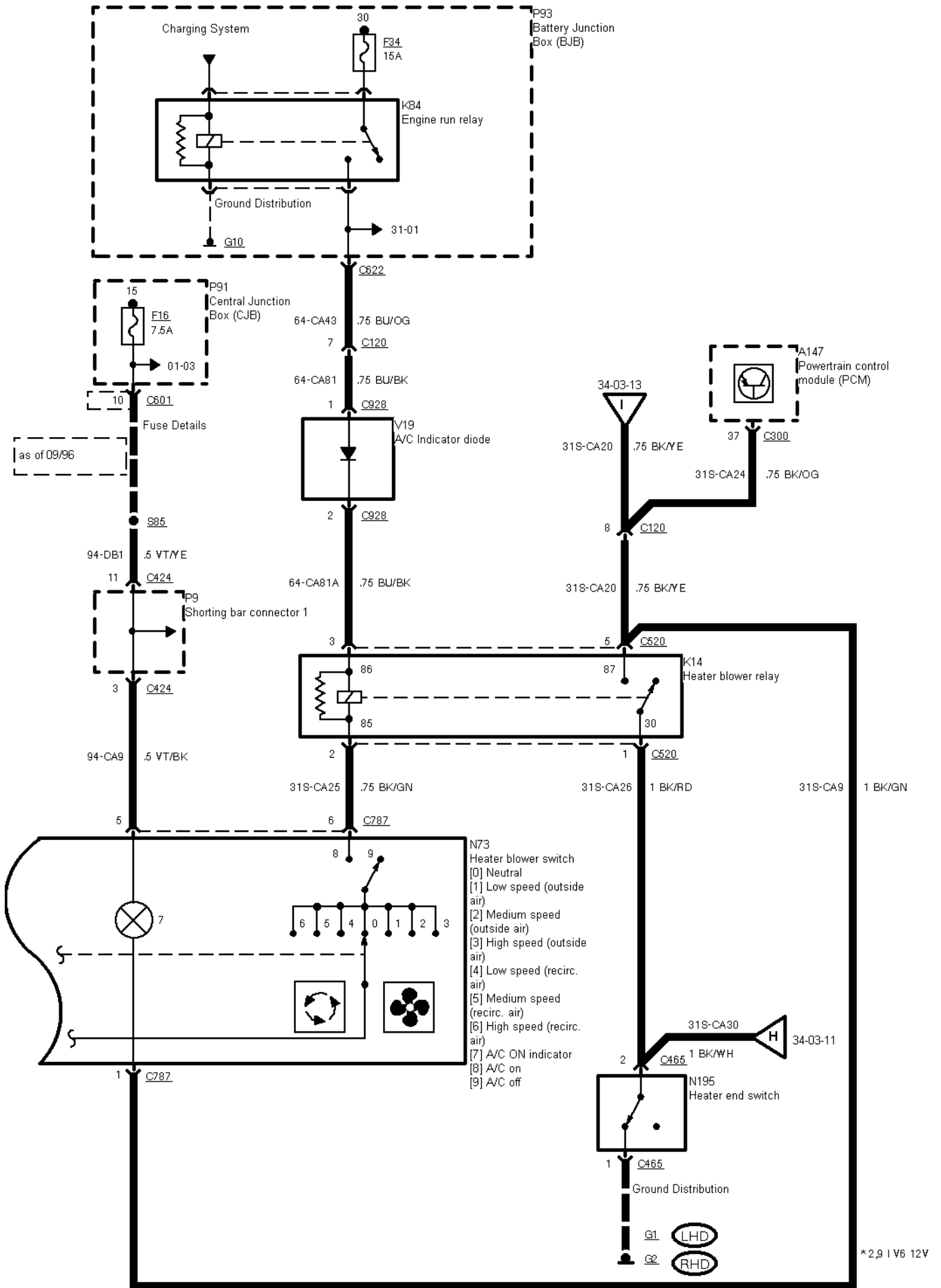

34-03-013 , Air Conditioning (03/96 ->) , Without SATC module, TCI Diesel as of 09/96

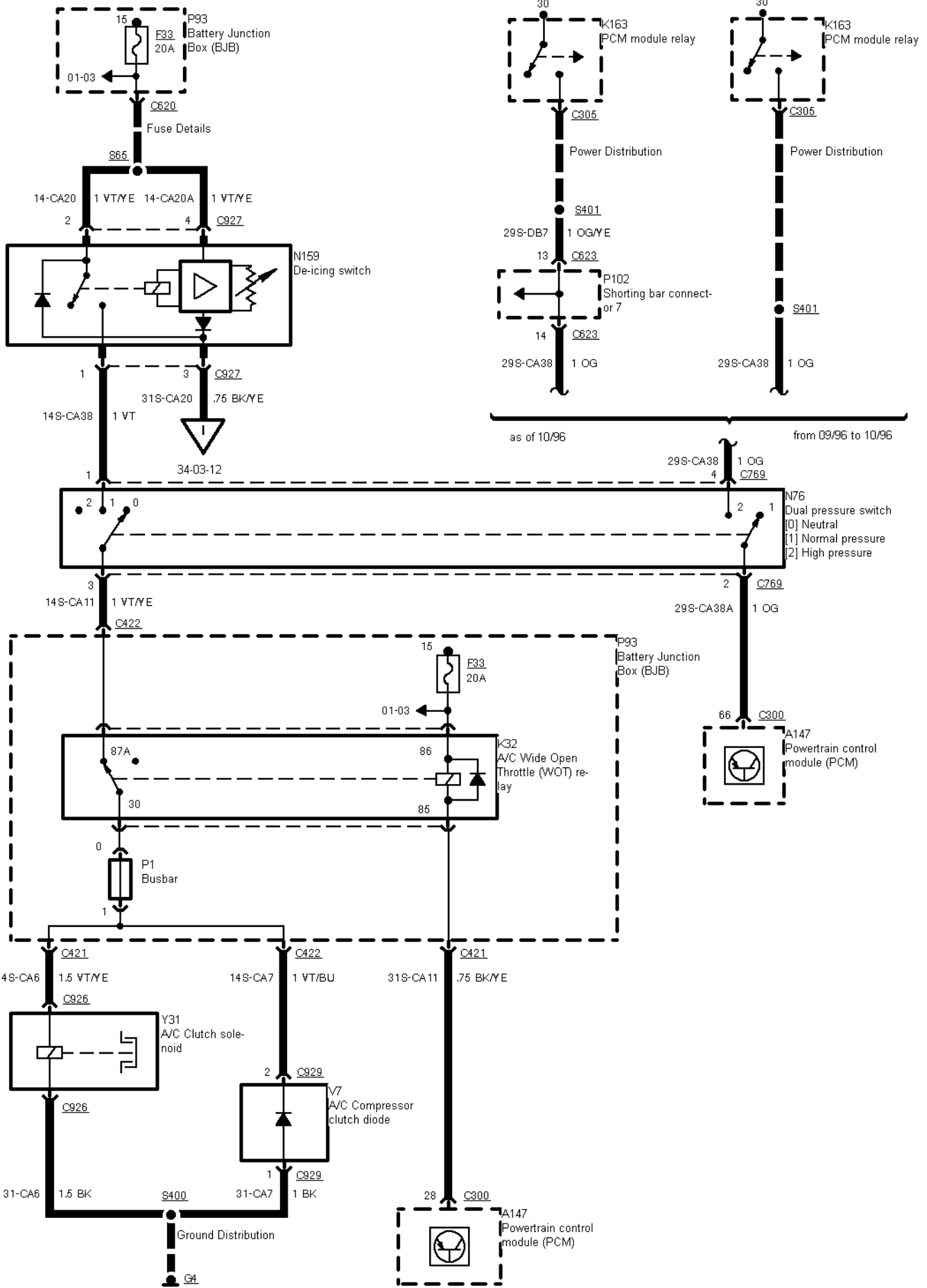

34-03-014 , Air Conditioning (03/96 ->), Engine cooling fan, TCI Diesel as of 09/96

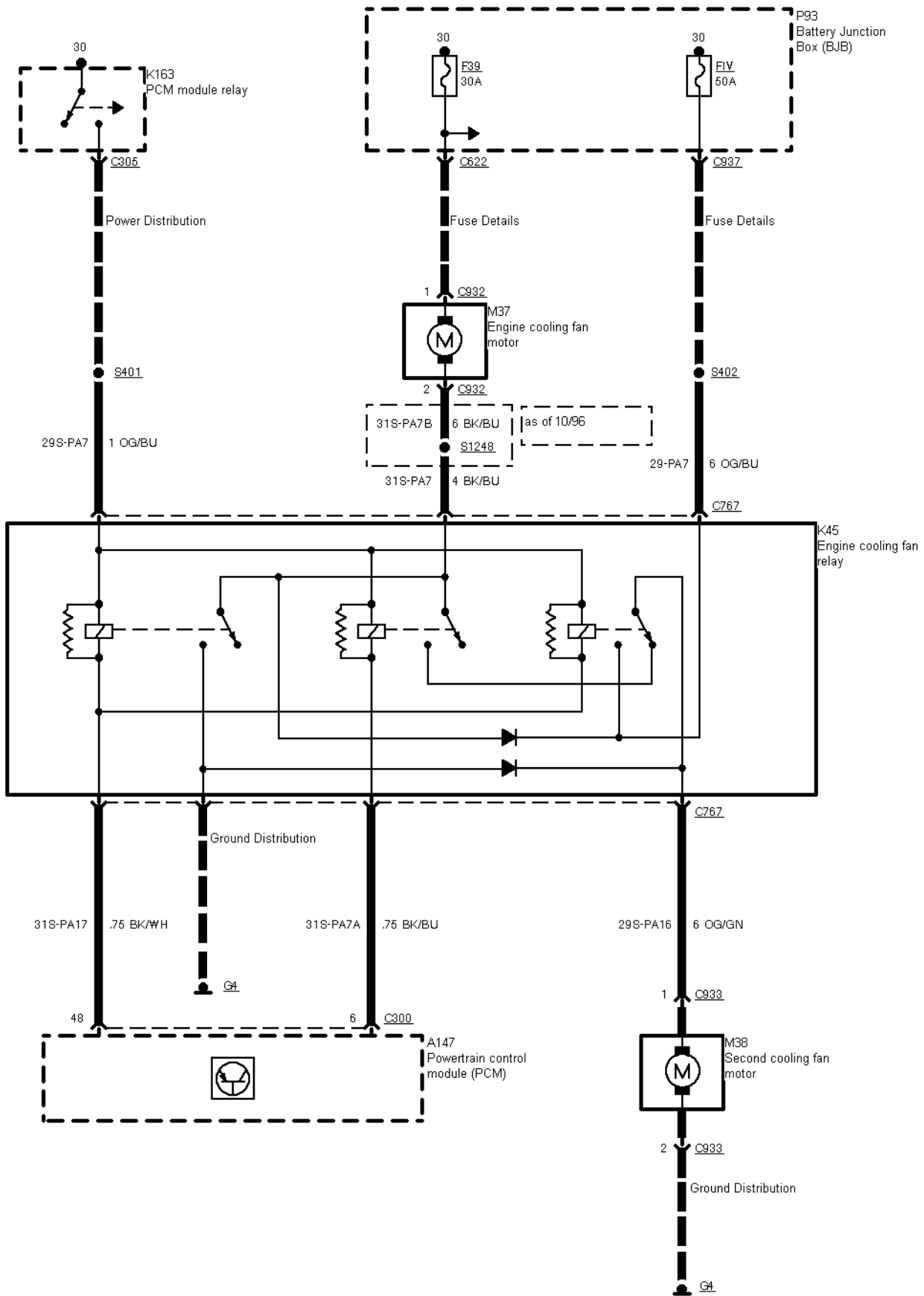

2 Circuit Description