

34-04-001 , Air Conditioning with SATC , Power, heater blower motor

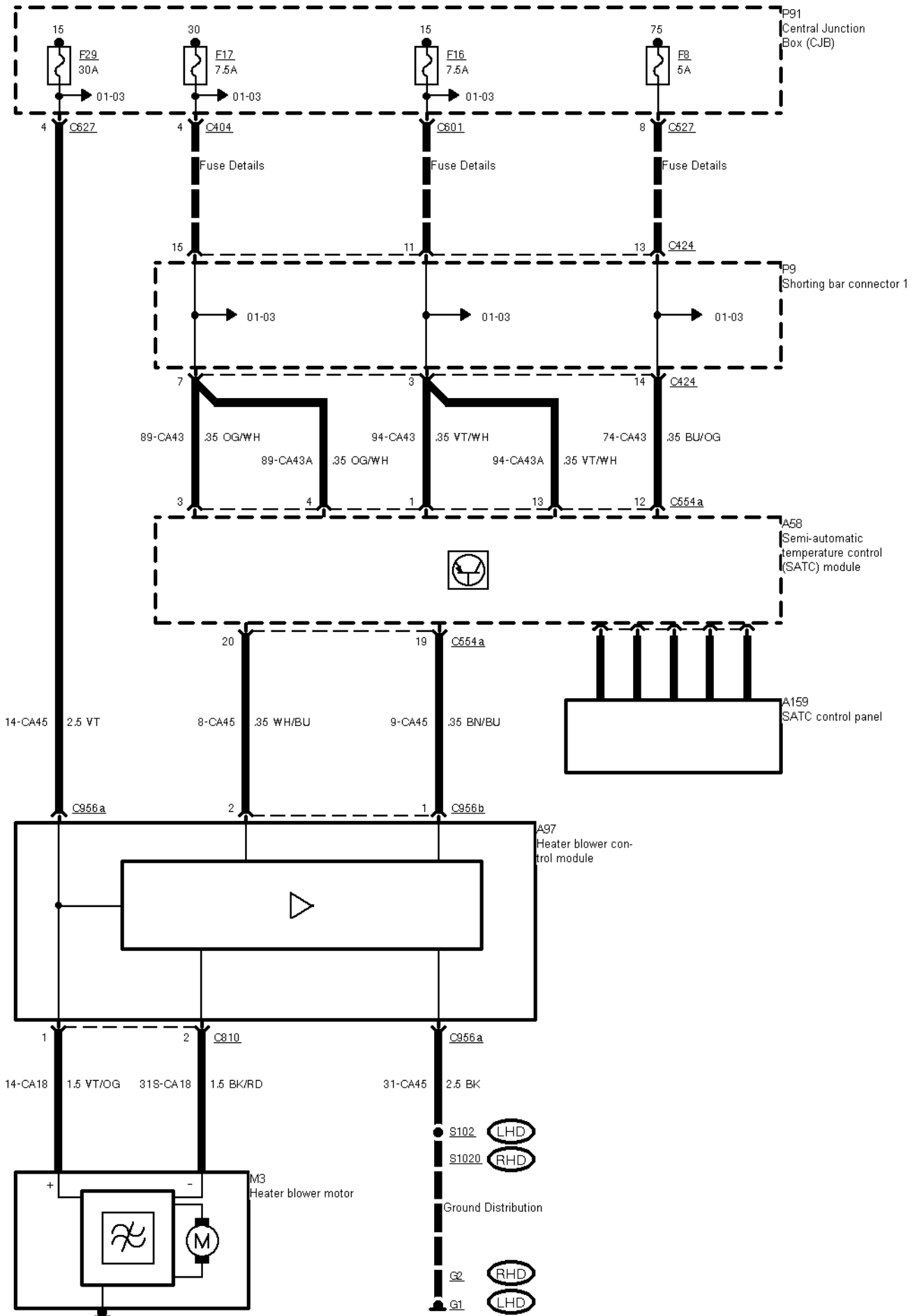

34-04-002 , Air Conditioning with SATC , Sensors

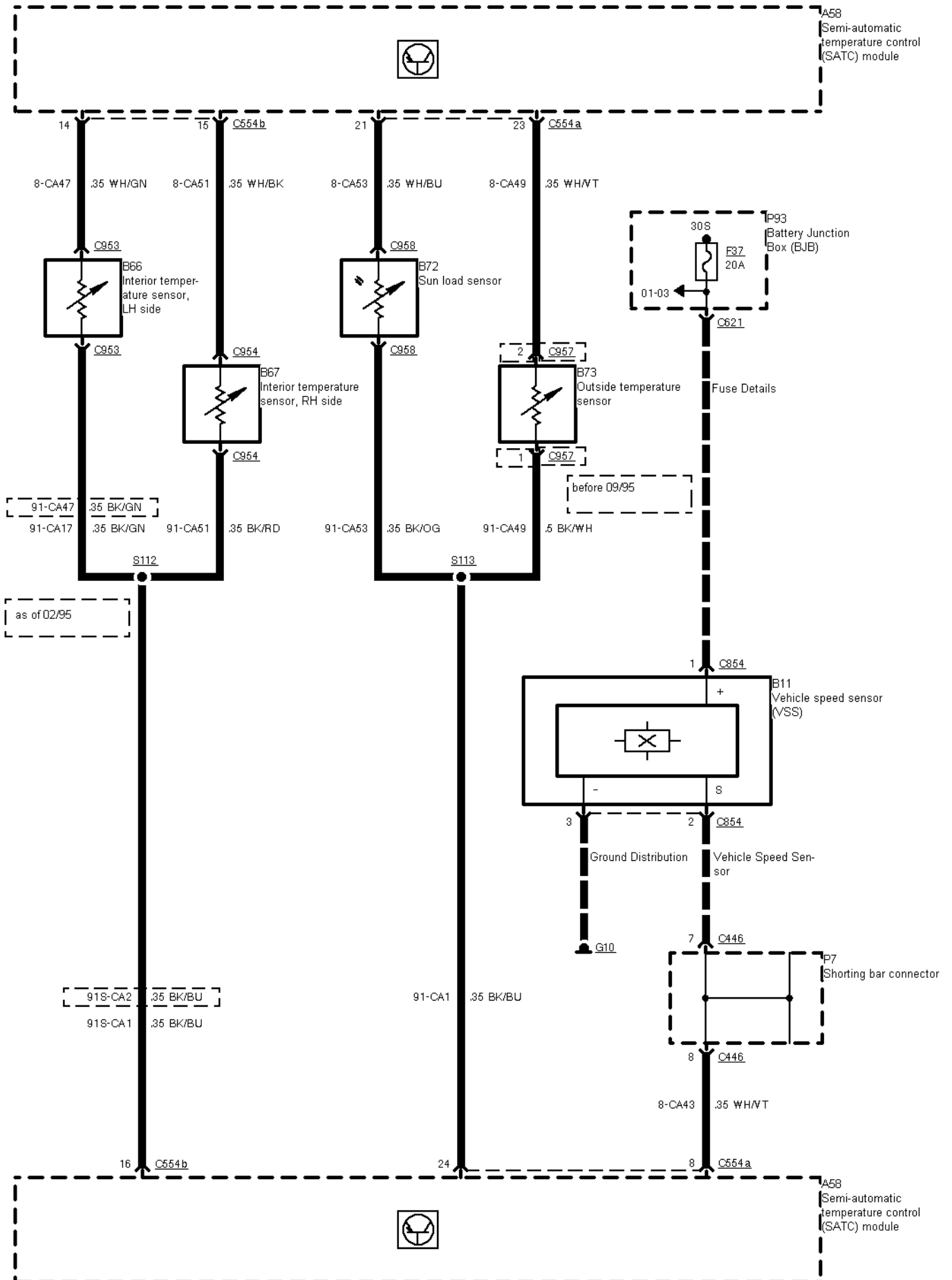

34-04-003 , Air Conditioning with SATC , Door motors

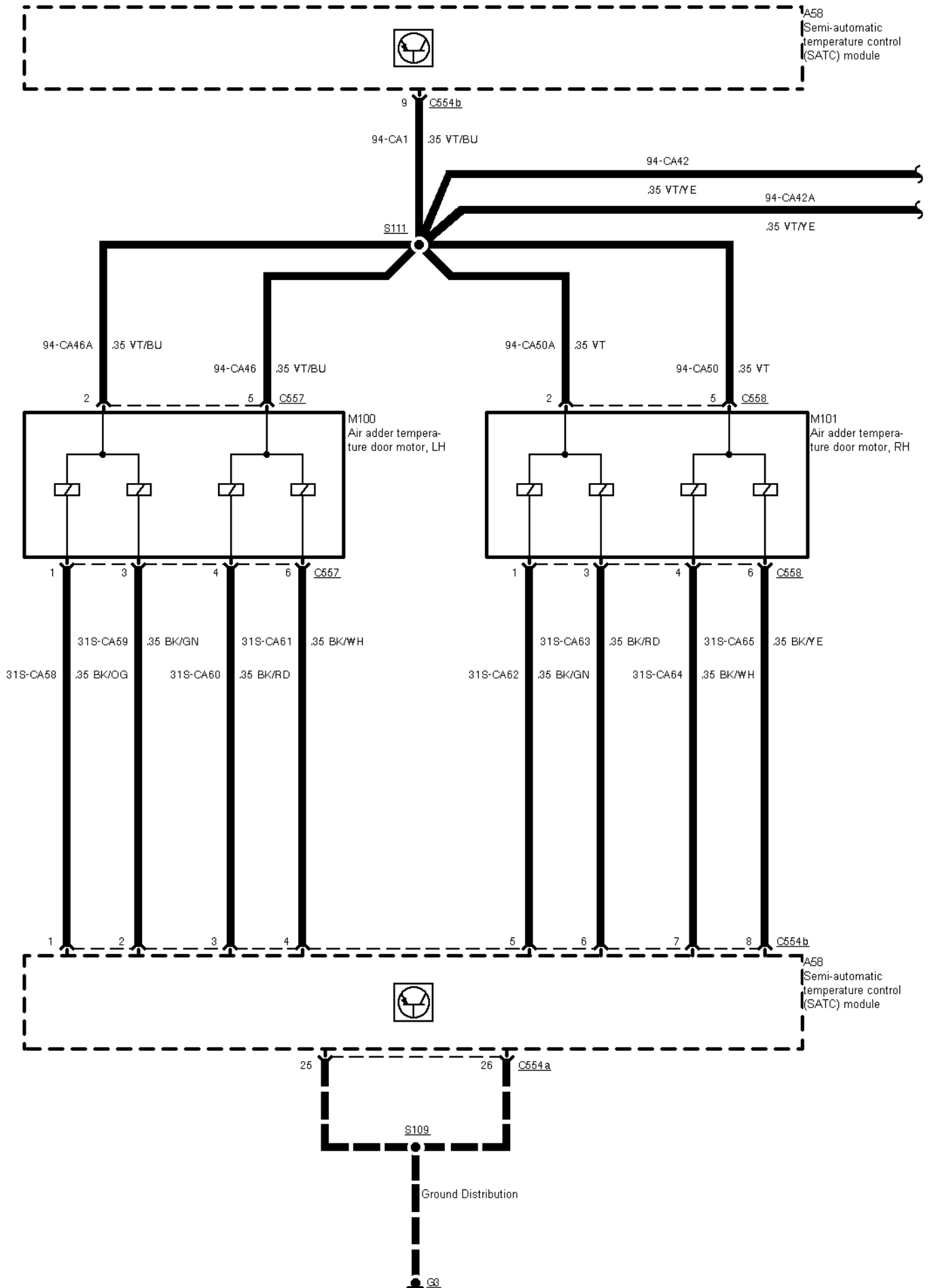

34-04-004 , Air Conditioning with SATC , Door motors

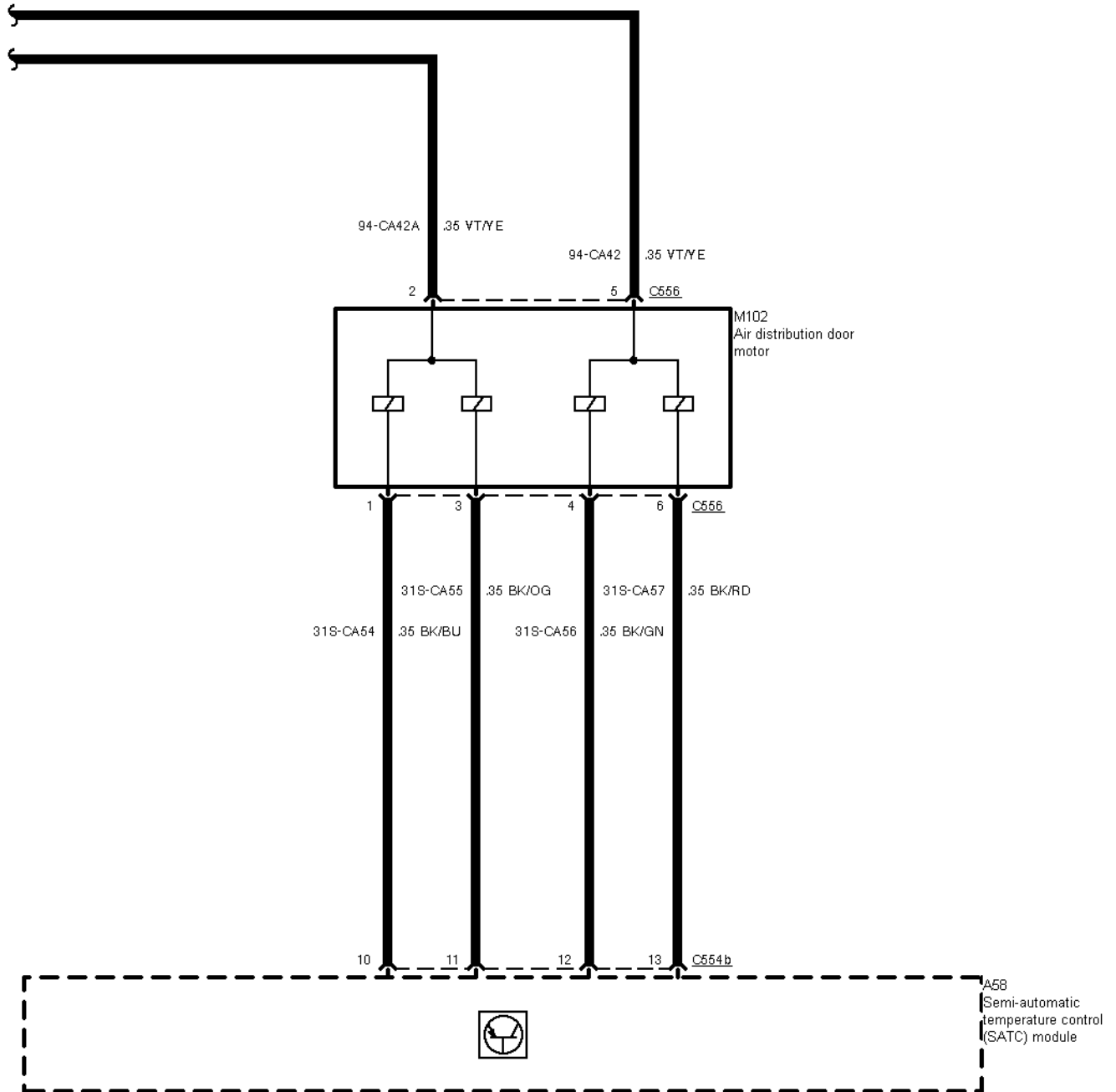

34-04-005 , Air Conditioning with SATC

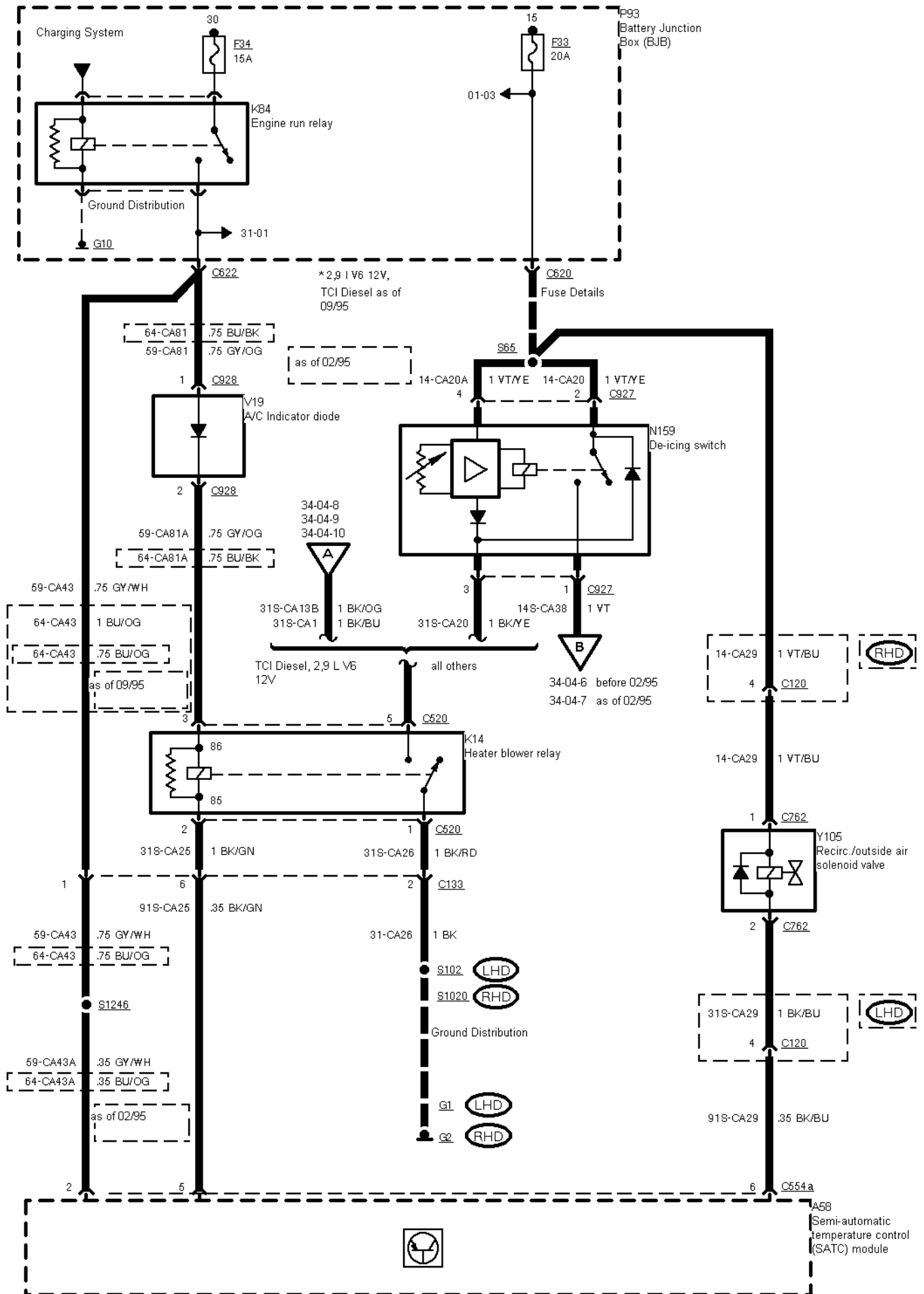

34-04-006 , Air Conditioning with SATC , Petrol engines before 02/95, except 2,9 I V6 12V

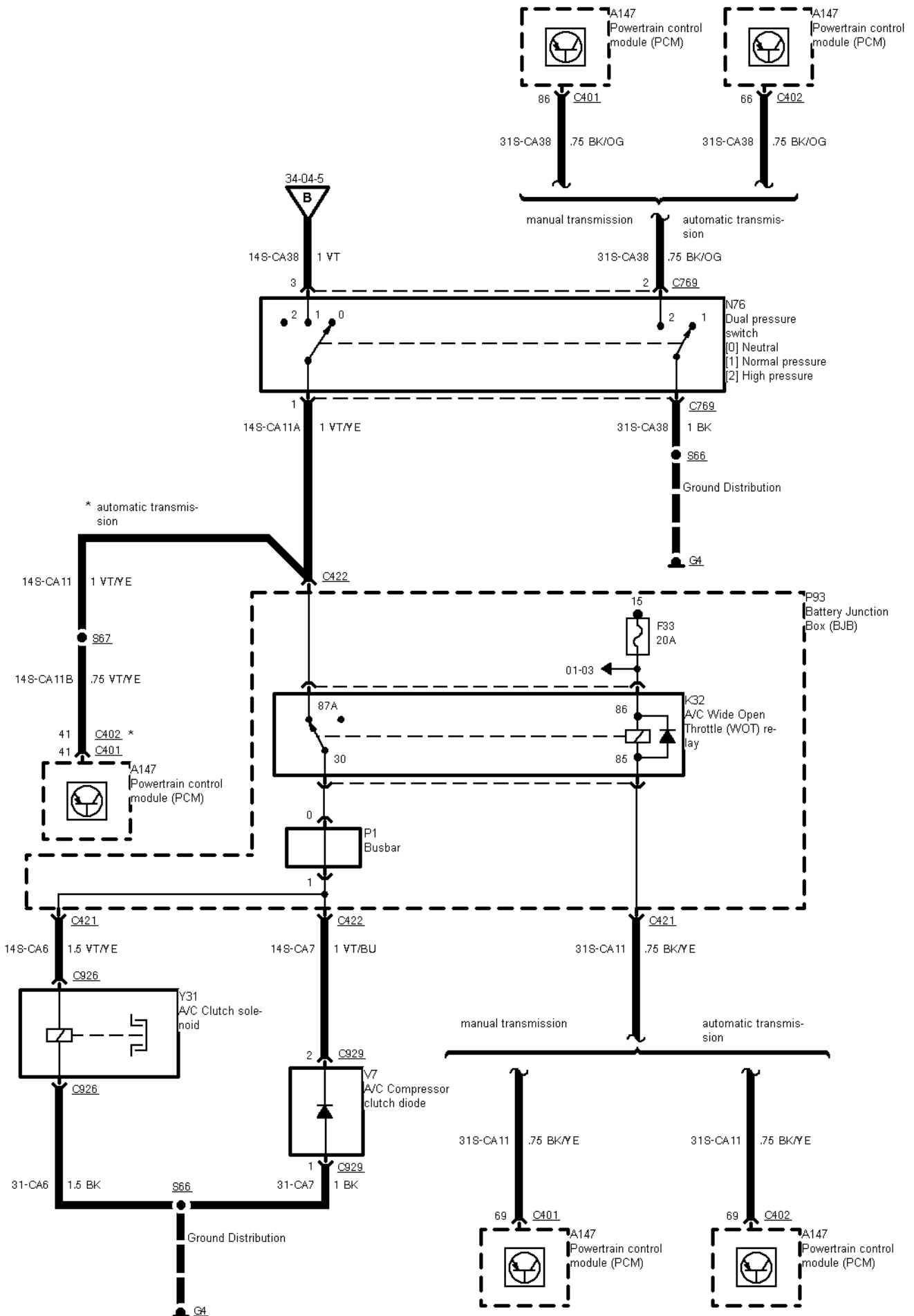

34-04-007 , Air Conditioning with SATC , Petrol engines as of 02/95, except 2,9 I V6 12V

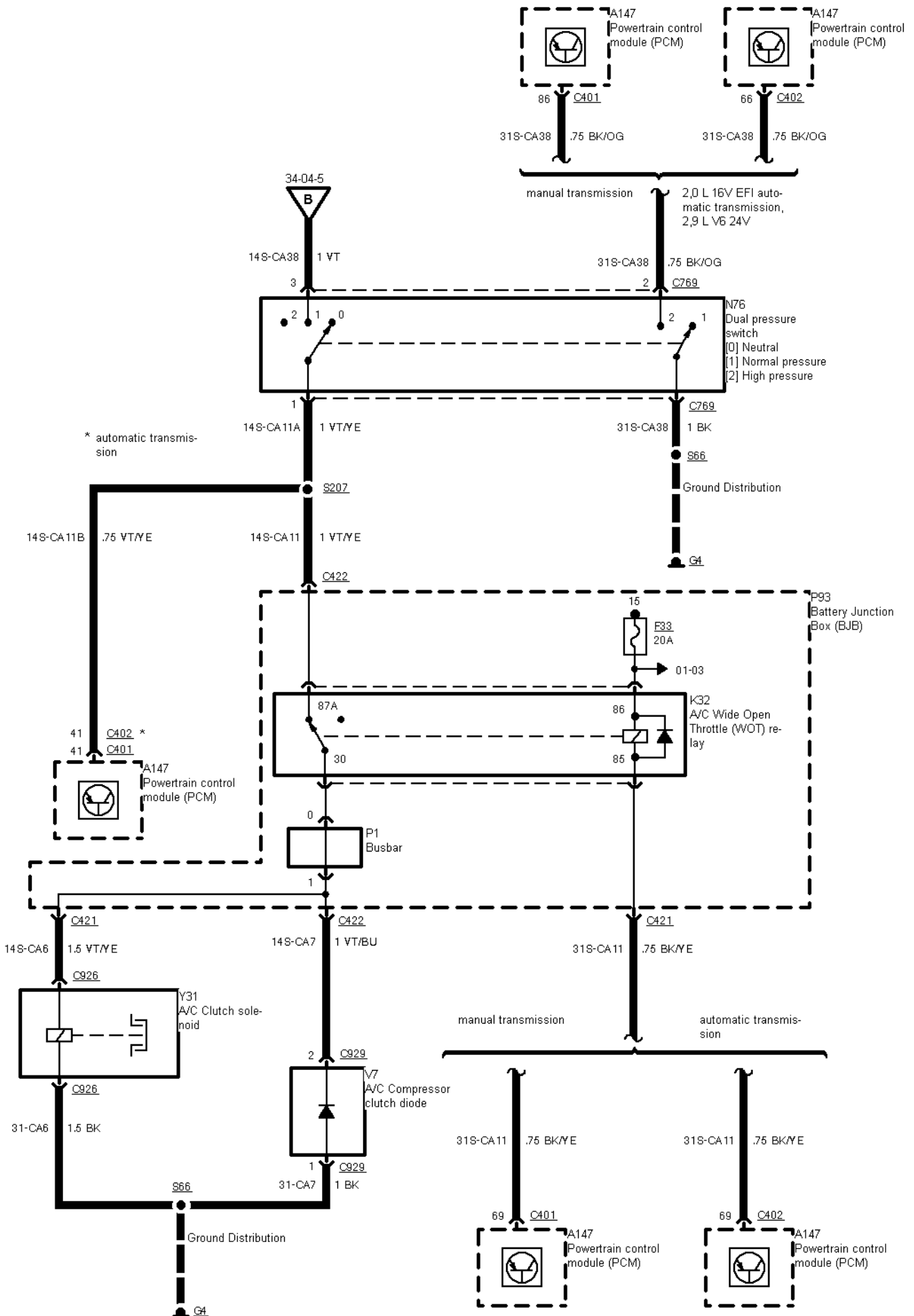

34-04-008 , Air Conditioning with SATC , TCI Diesel before 02/95 and as of 09/95, TCI Diesel without PATS from 02/95 to 09/95

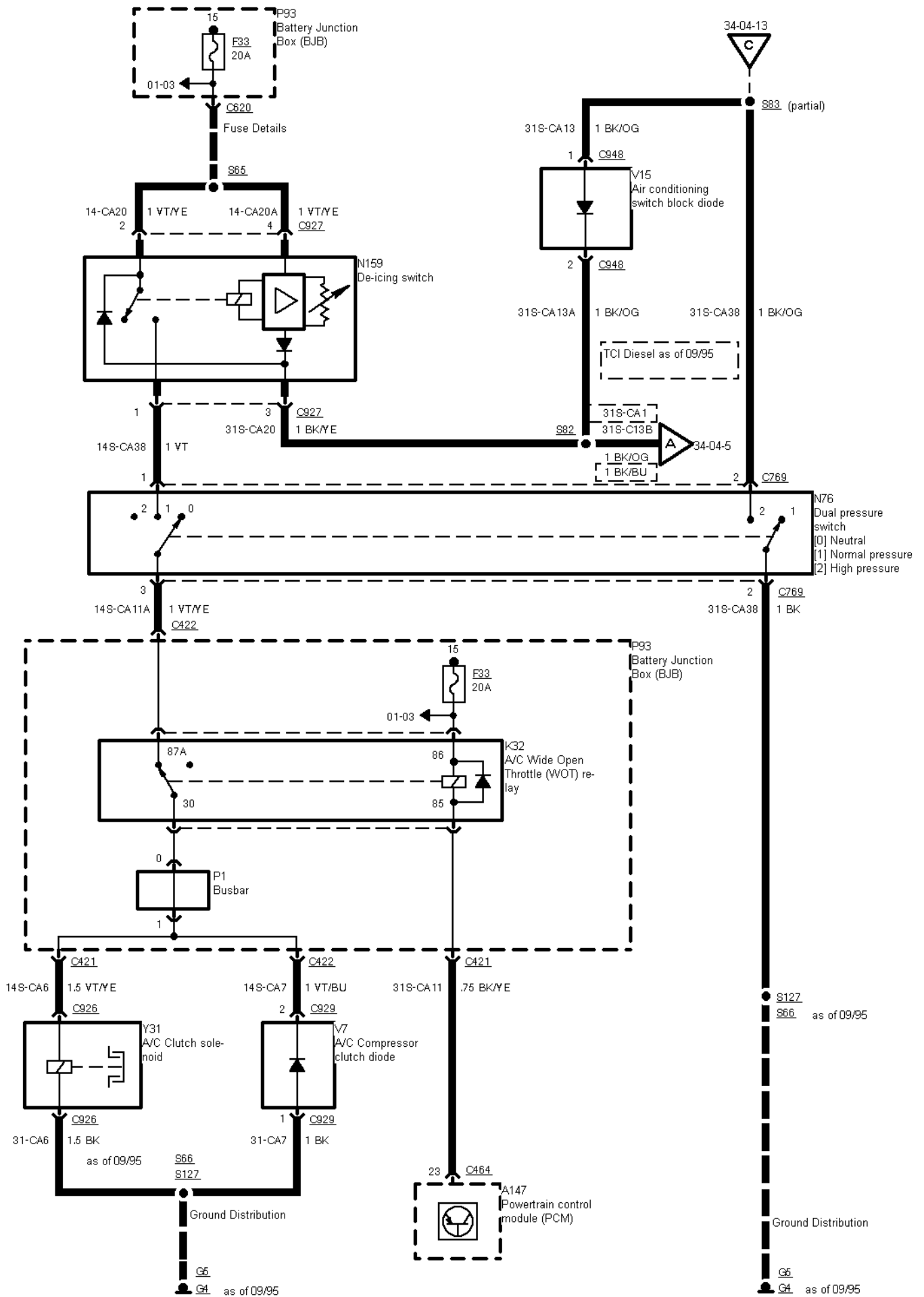

34-04-009 , Air Conditioning with SATC , TCI Diesel with PATS from 02/95 to 09/95

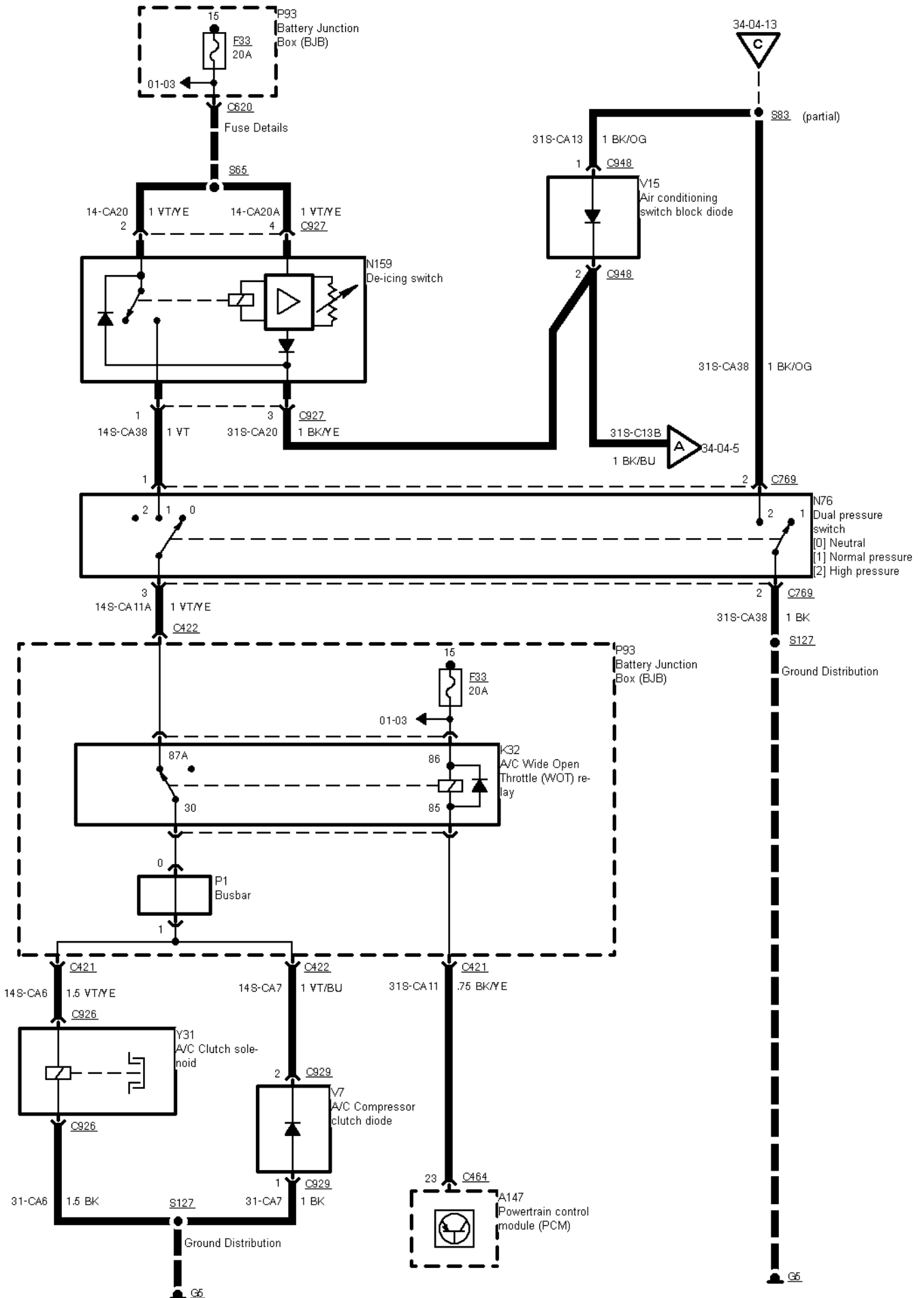

34-04-010 , Air Conditioning with SATC , 2,9 I V6 12V

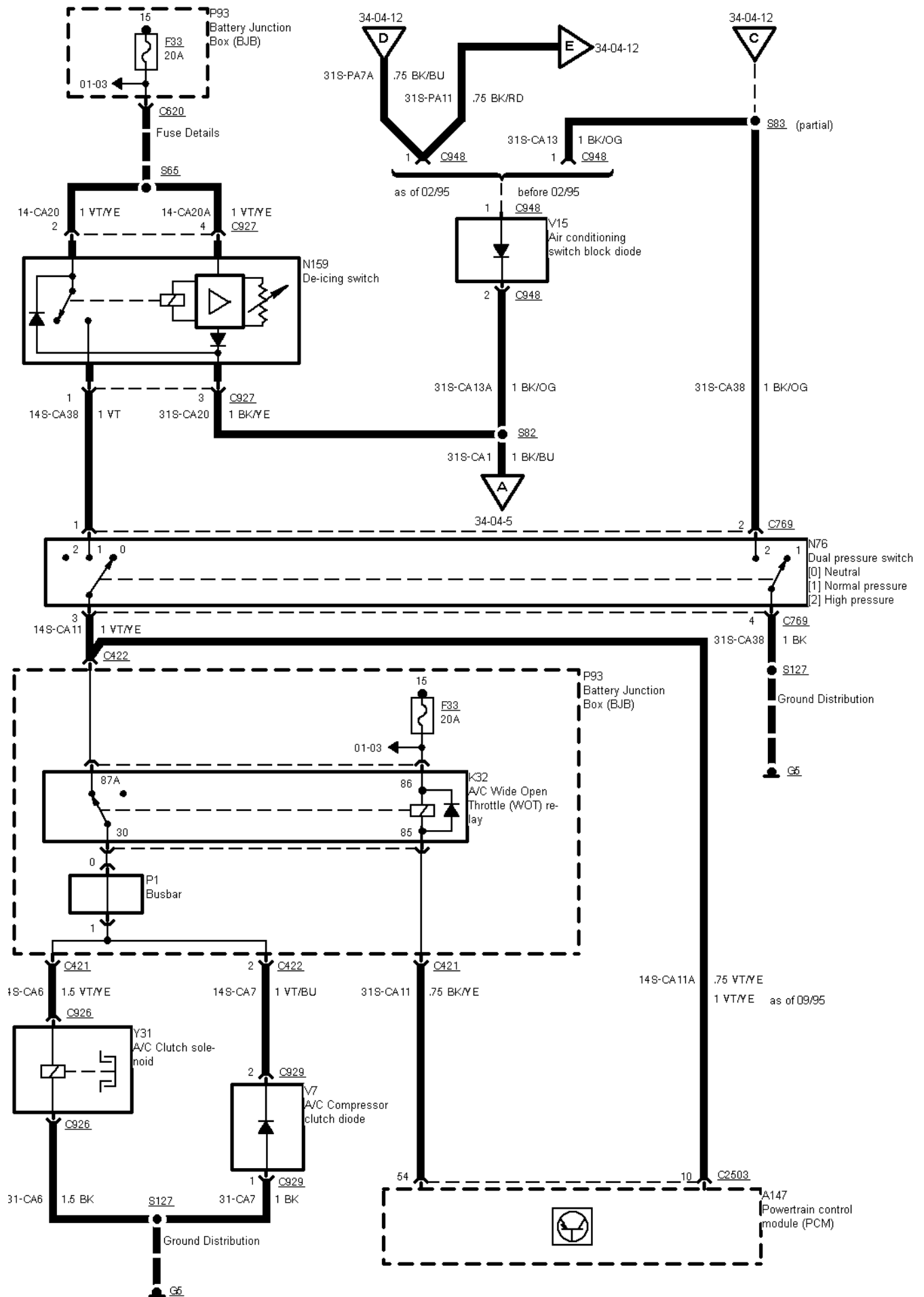

34-04-011 , Air Conditioning with SATC , Engine cooling fan, except TCI Diesel, except 2,9 I V6 12V

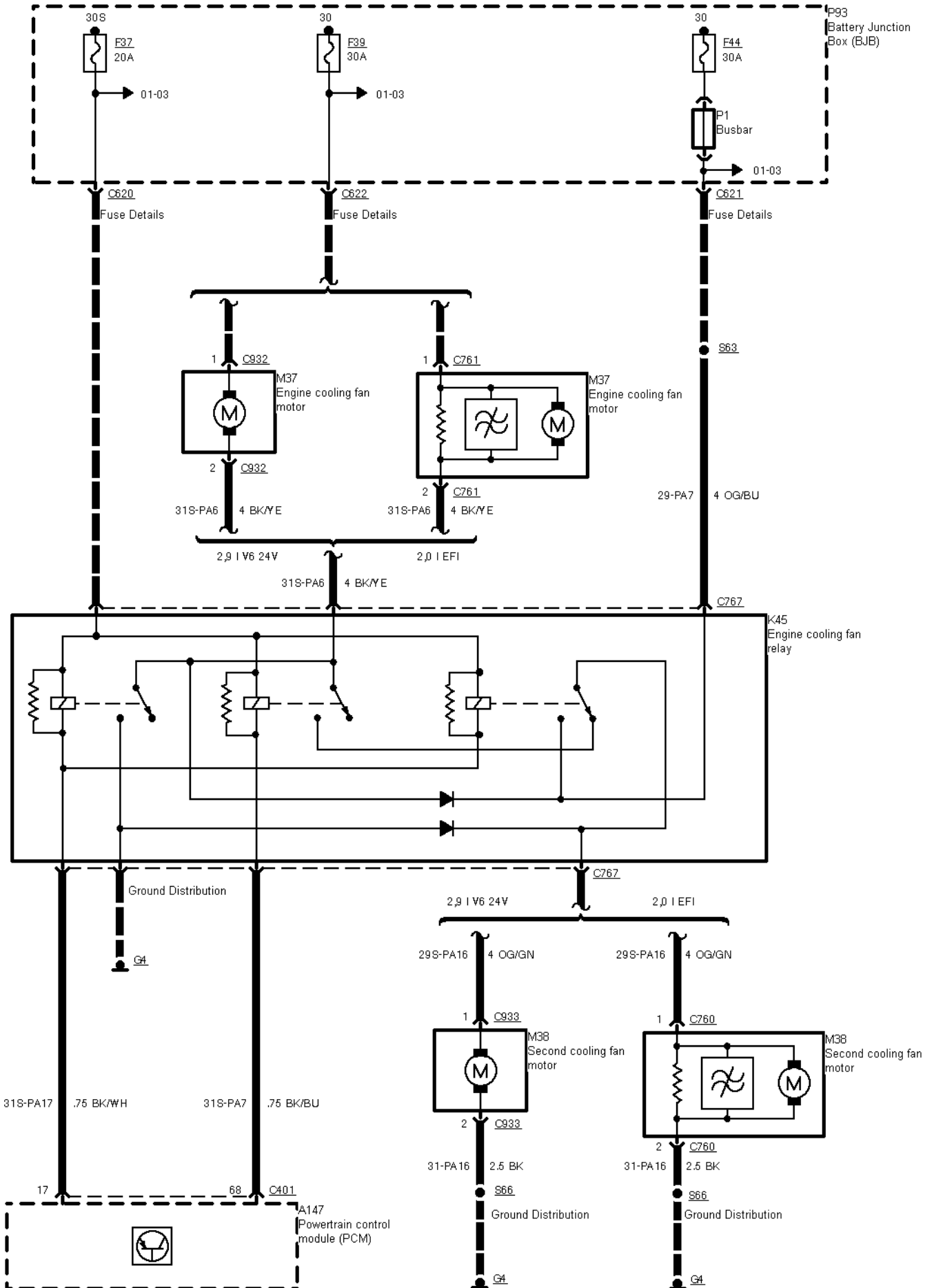

34-04-013 , Air Conditioning with SATC , Engine cooling fan, TCI Diesel

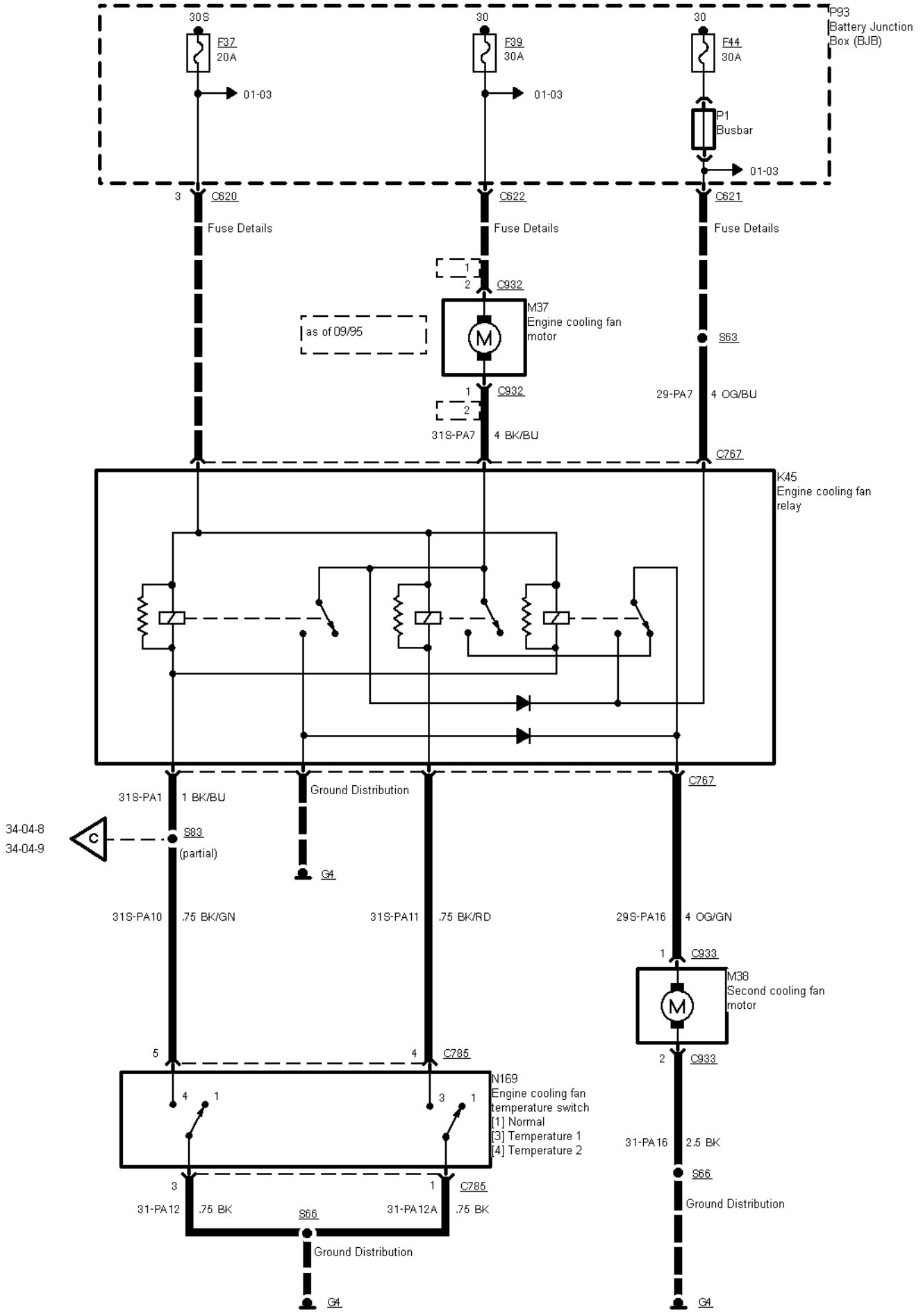

2 Circuit Description
