

# 33-01-001 , Entry Illumination

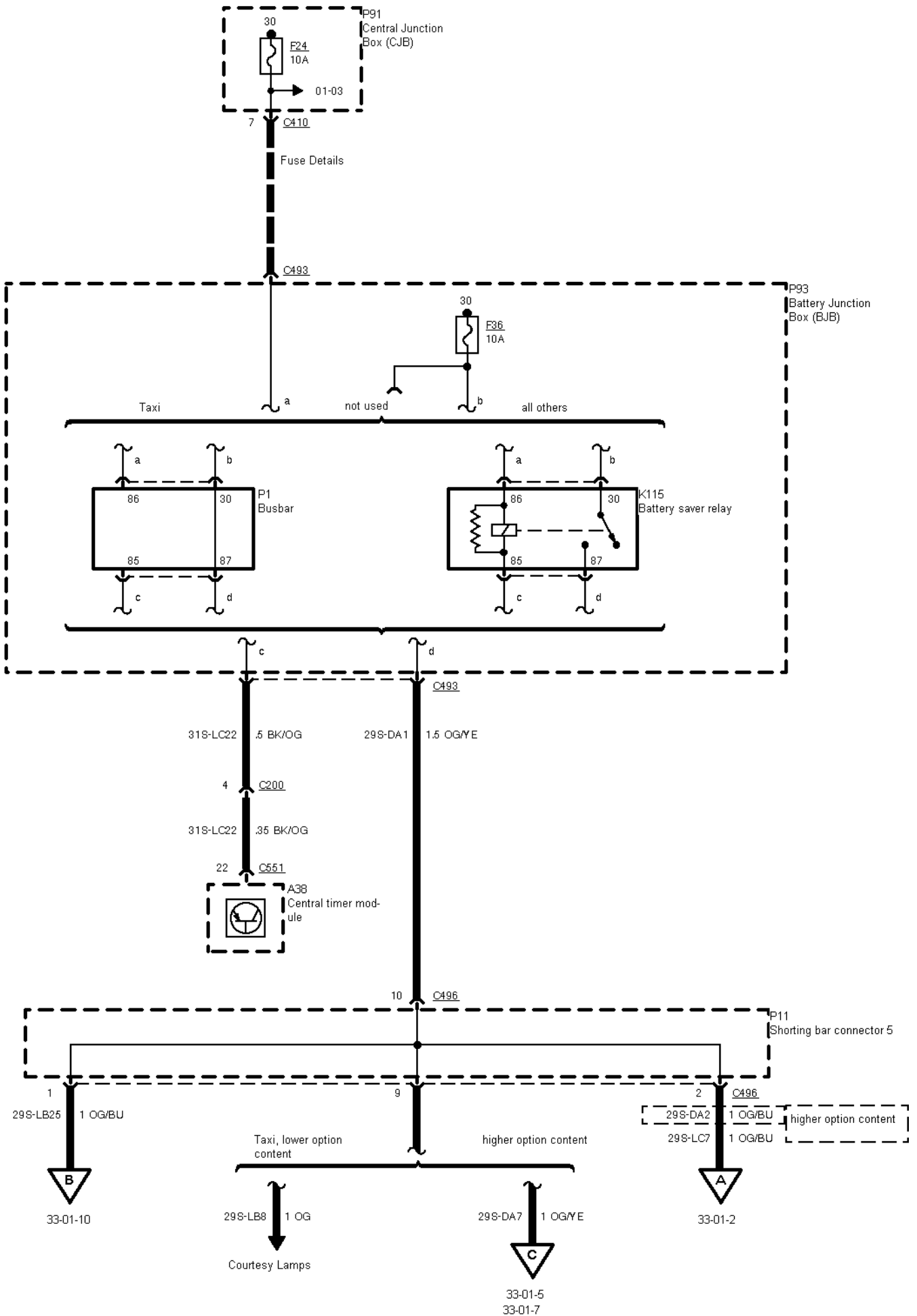

# 33-01-002 , Entry Illumination

Lower option content

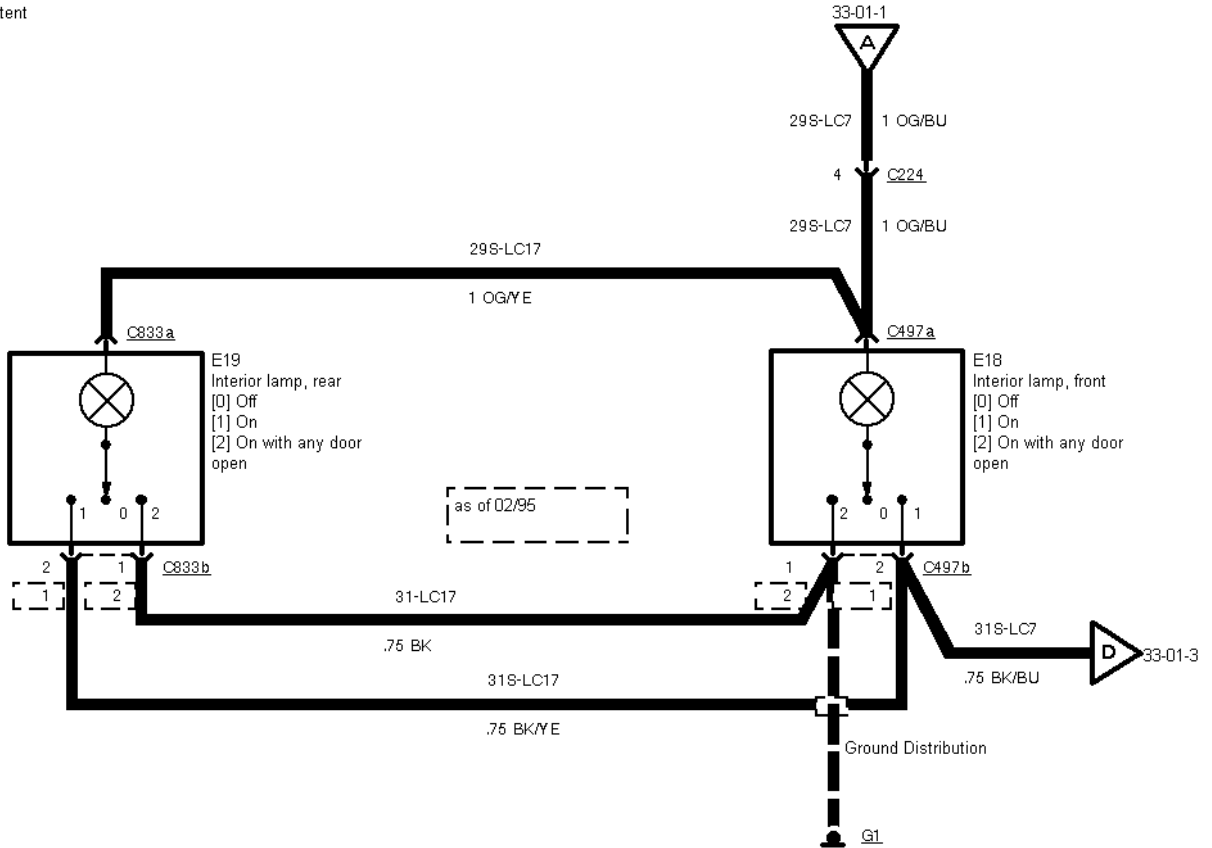

Higher option content

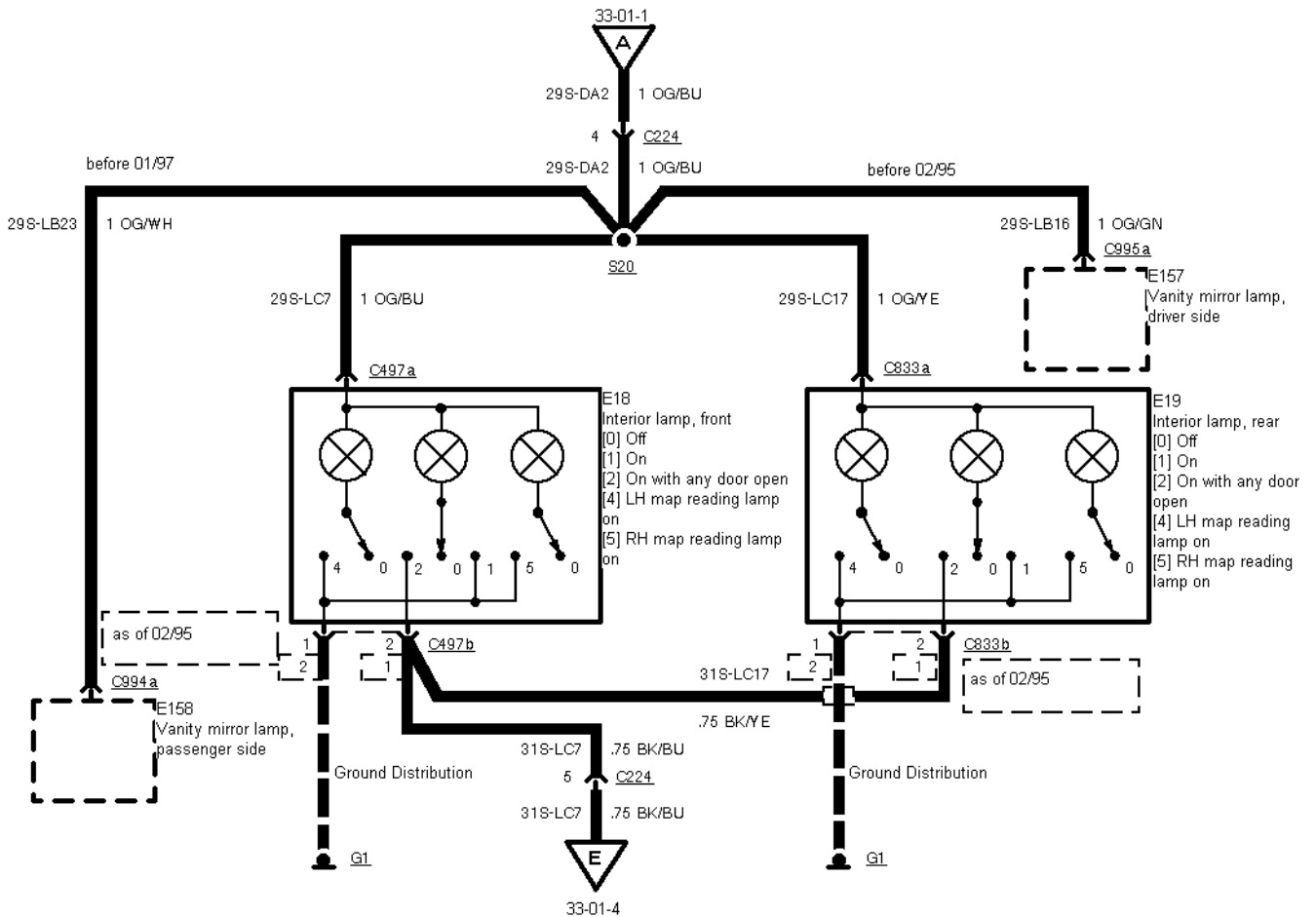

33-01-003 , Entry Illumination , Lower option content before 01/97, all vehicles as of 01/97

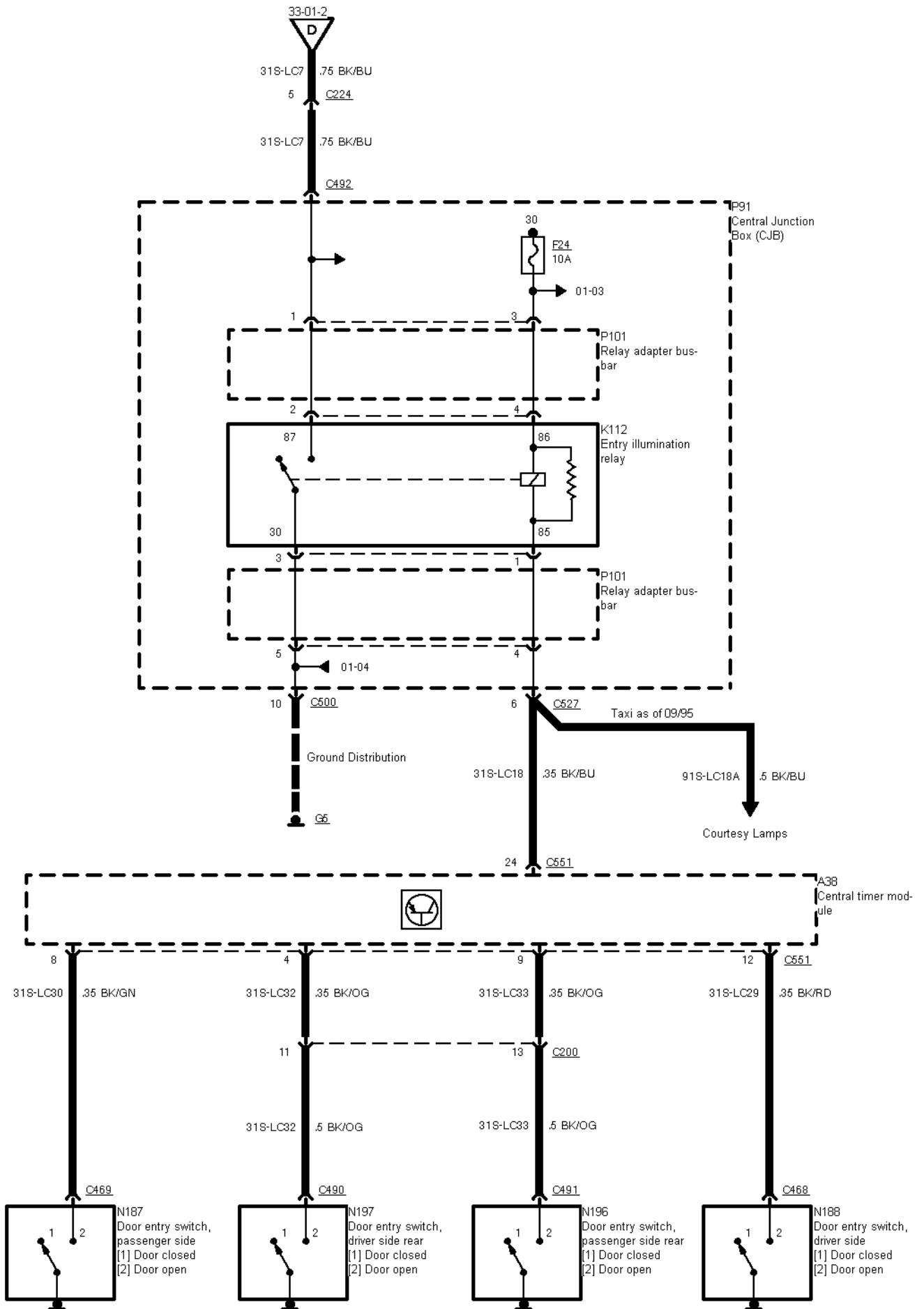

33-01-004 , Entry Illumination , Higher option content before 01/97

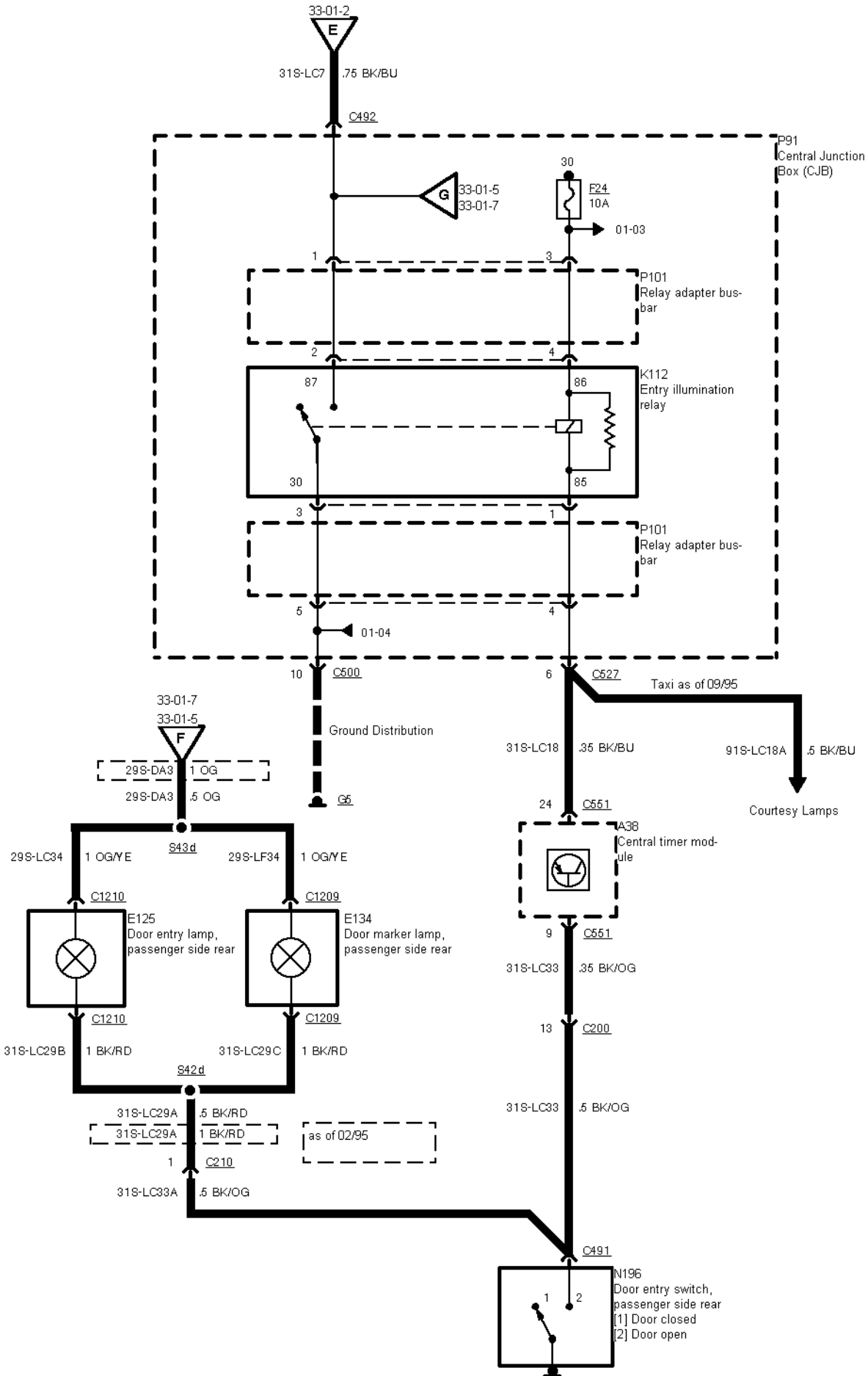

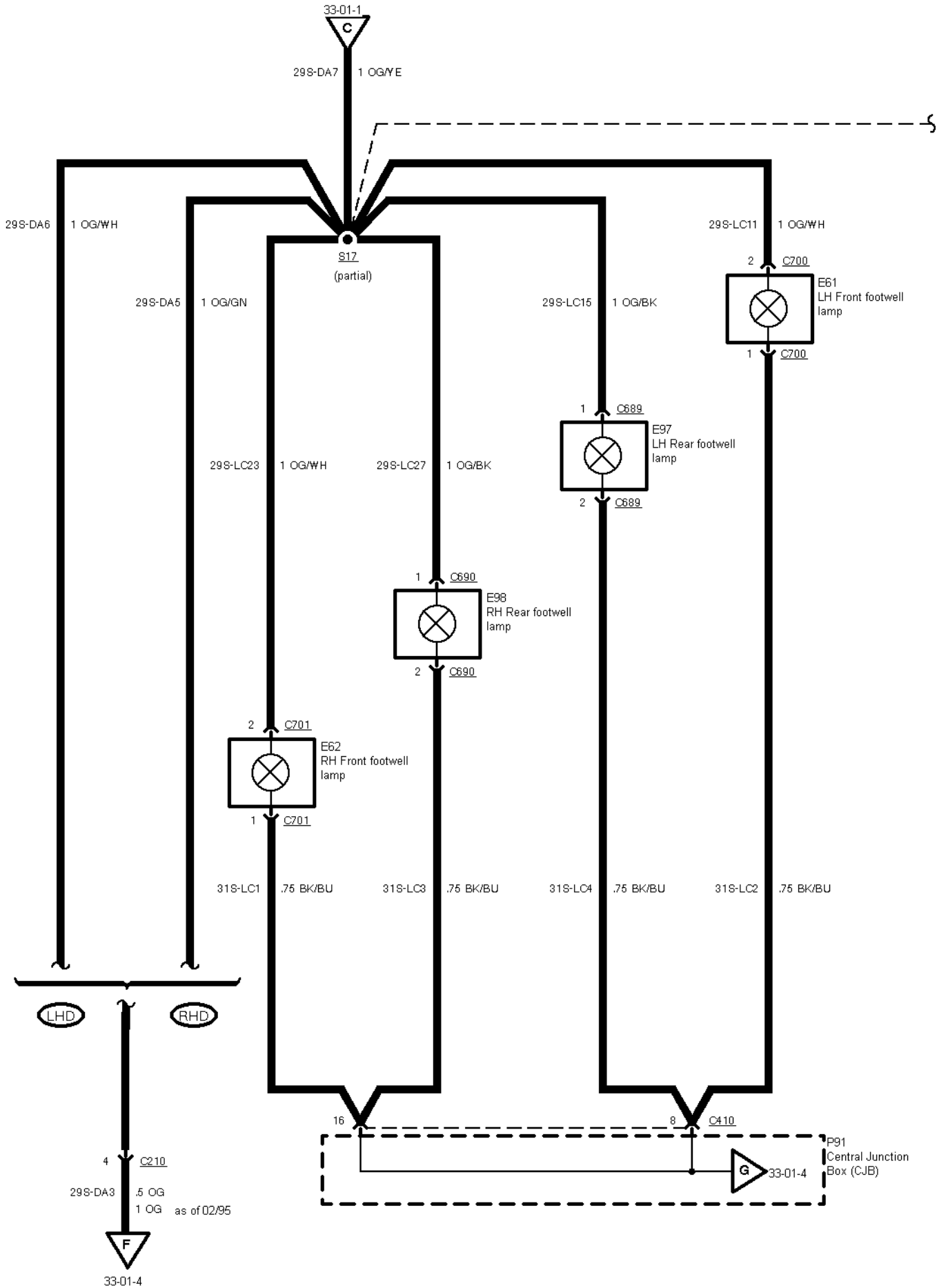

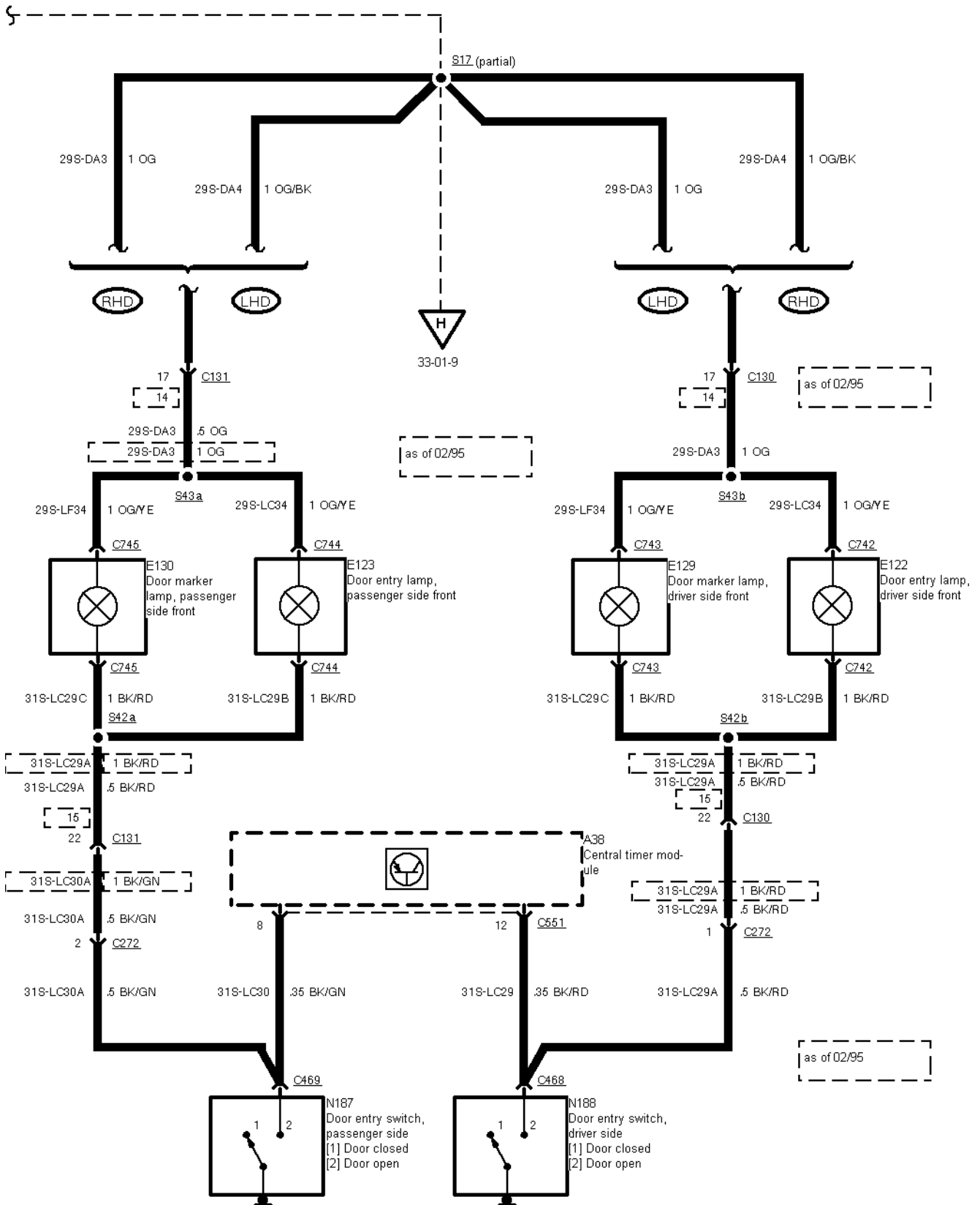

33-01-007 , Entry Illumination , Higher option content as of 10/96

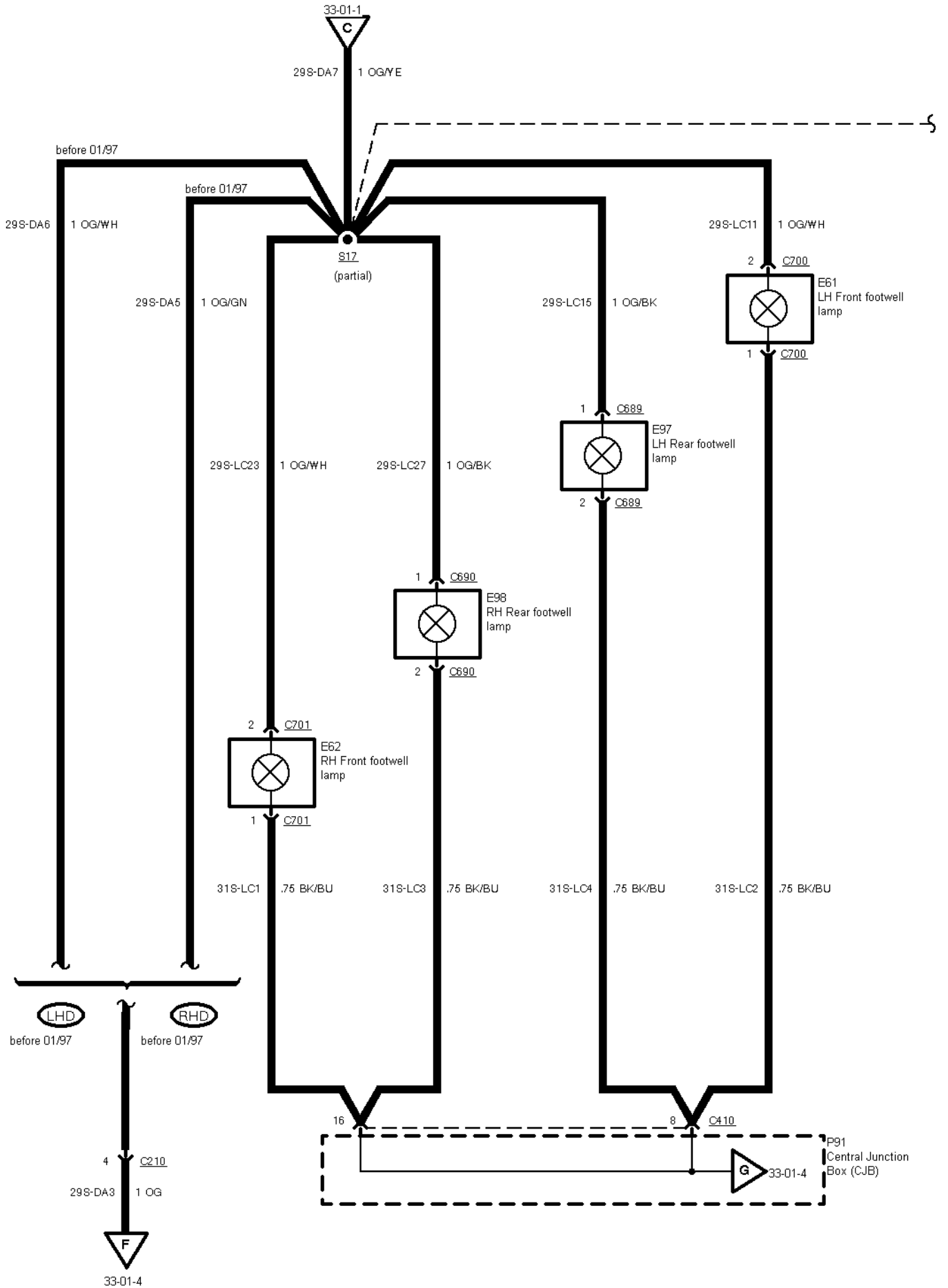

33-01-008 , Entry Illumination , Higher option content from 10/96 to 01/97

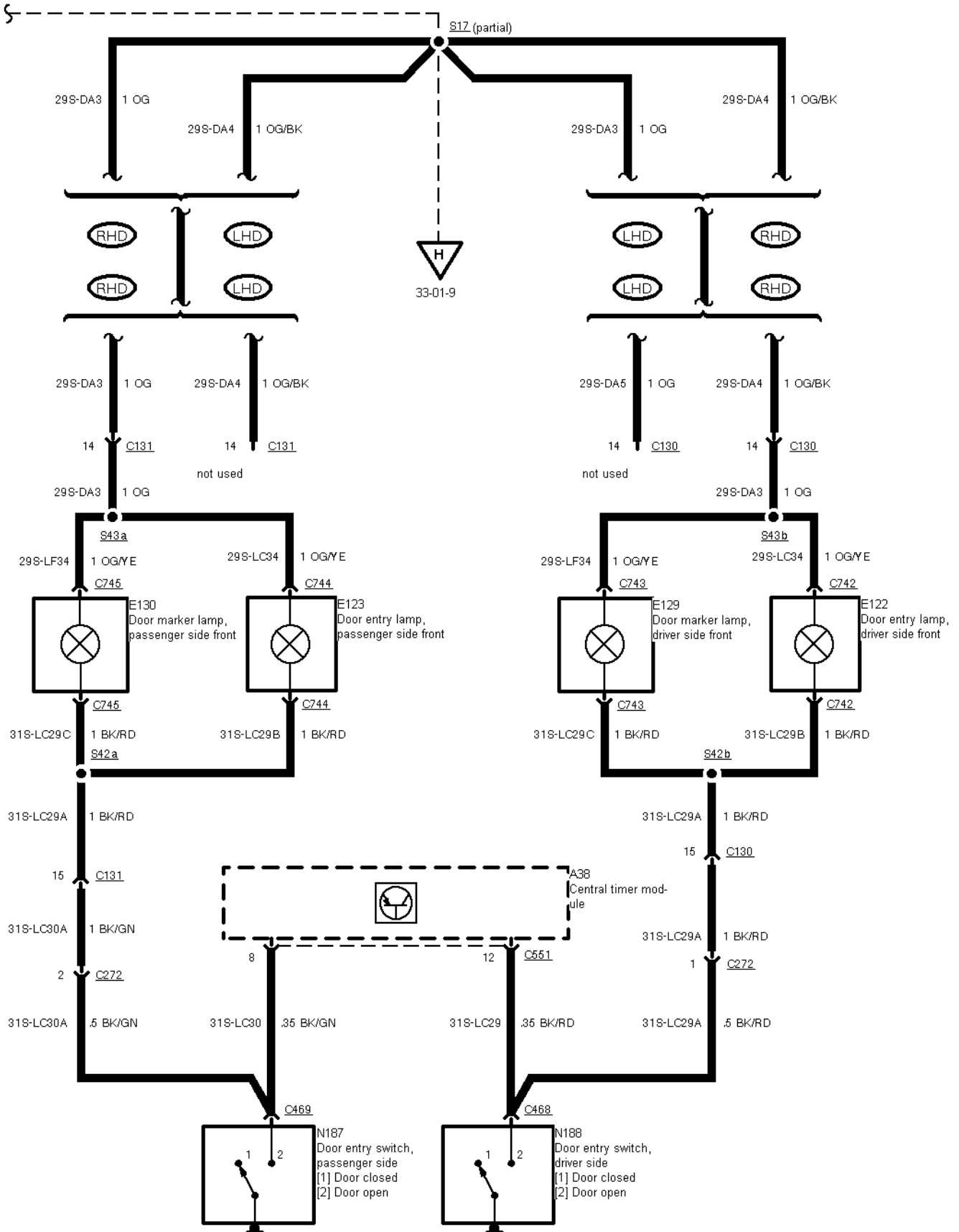

33-01-009 , Entry Illumination , Higher option content

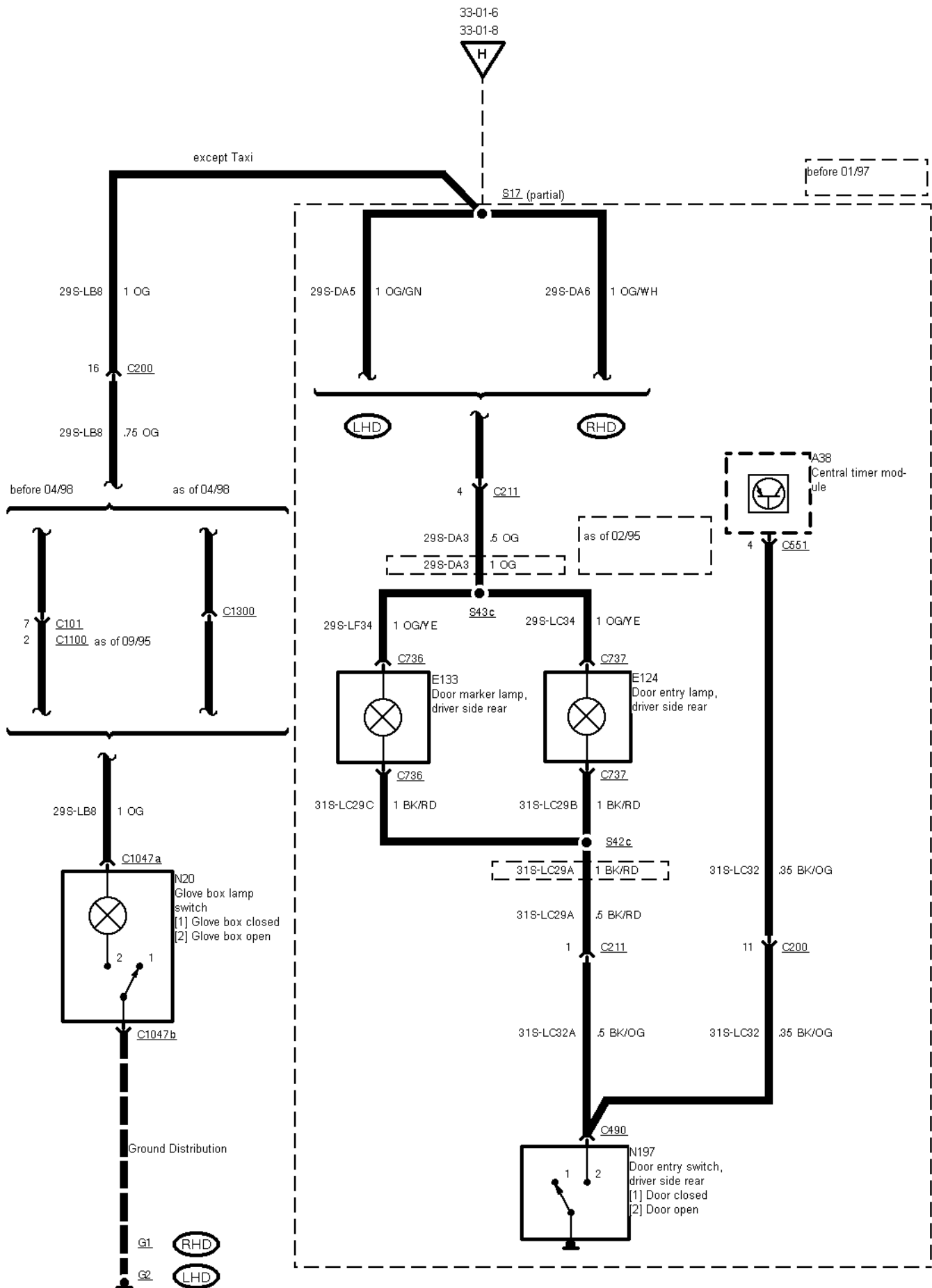

33-01-010 , Entry Illumination

